

GANIL Data Acquisition System

Bruno RAINE

Groupe **A**cquisition pour la **P**hysique
raine@ganil.fr

GANIL Data Acquisition Group (GAP)

■ Group Acquisition pour la Physique

- ◆ Hardware : M. Blaizot, A. Boujrad, P. Bourgaut
C. Houarner, M. Tripon, G. Wittwer
- ◆ Software : G. Lebertre, L. Legeard, L. Martina
C. Maugeais, B. Raine, F. Saillant

■ Missions

◆ Experiment running

- ✦ Support physicists in implementation, use and setup of acquisition configurations

◆ Electronics and software studies and design

- ✦ Ganil acquisition
triggers, converter, clock, synchronization, ...
- ✦ Collaborations for detectors @ GANIL :
INDRA, EXOGAM, MUST2
- ✦ Software developments
Electronics setup, readout, data analysis, storage

GANIL Data Acquisition Group (GAP)

■ Group Acquisition pour la Physique

- ◆ Hardware : M. Blaizot, A. Boujrad, P. Bourgault, C. Houarner, M. Tripon, G. Wittwer
- ◆ Software : G. Lebertre, L. Legeard, L. Martina C. Maugeais, B. Raine, F. Saillant

■ Missions

◆ Experiment running

- ✦ Support physicists in implementation, use and setup of acquisition configurations

◆ Electronics and software studies and design

- ✦ Ganil acquisition
 - triggers, converter, clock, synchronization, ...
- ✦ Collaborations for detectors @ GANIL :
 - INDRA, EXOGAM, MUST2
- ✦ Software developments
 - Electronics setup, readout, data analysis, storage

Detector Coupling with CENTRUM

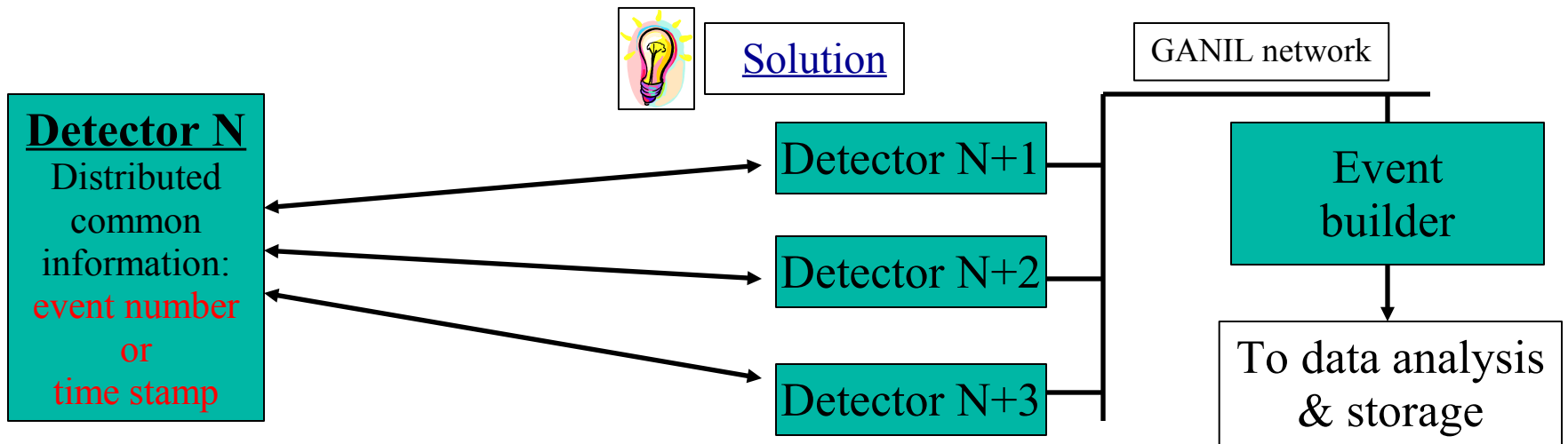
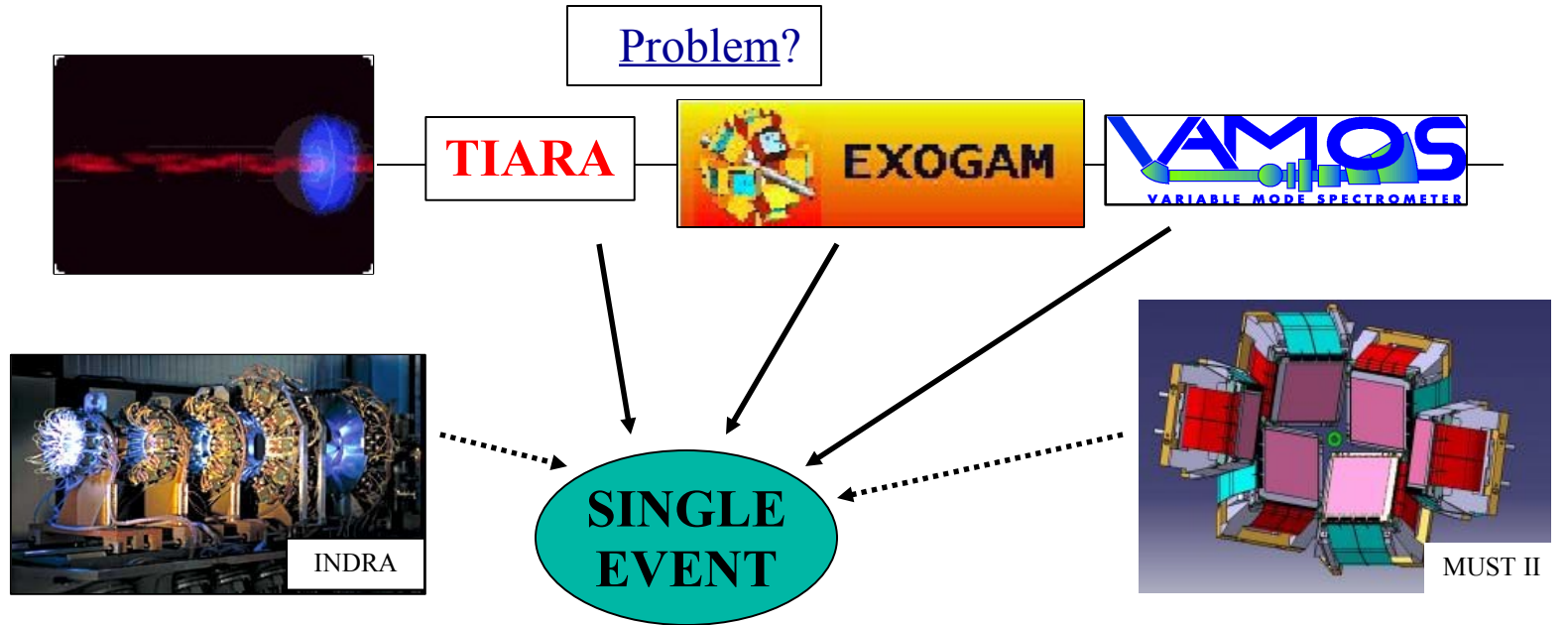

Detector Coupling with CENTRUM

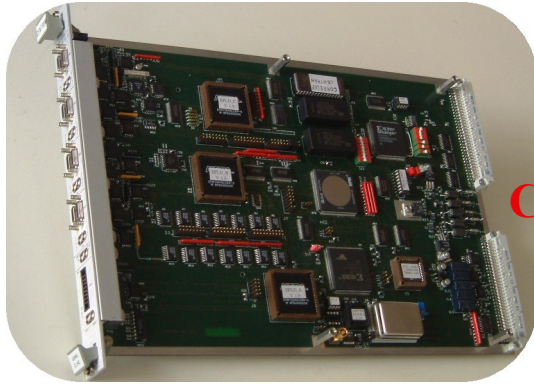

VXI-C CENTRUM module

Clock & Event Number Transmitter Receiver Universal Module

Main features:

- ✓ Same module for both ends
- ✓ 32 bits event counter
 - clocked by VXI TTLTRG signal or via front panel NIM input
 - check for EXOGAM event number validity
- ✚ 48 bits absolute clock @ 100 MHz
 - 1 month experiment
 - TCXO stability : 1 ppm
- ✚ 8 front panel serial channels
 - 1 receiver channel (when used as slave module)
 - programmable delay on each tagging signal input (up to 500 ns)
 - 5 short distance transmitter channels (up to 25 meters)
 - 2 long distance transmitter channels (up to 100 meters)

Detector Coupling with CENTRUM

Fully integrated in the GANIL DAQ with the "DAS" setup GUI

The screenshot displays the GANIL DAS v10.07 software interface. The window title is "GANIL DAS v10.07 [Language : français(fr)] gamer". The menu bar includes "Fichier", "Utilitaires", "Mise à jour", "Acquisition", "Visualisation", "Réservé", and "Aide". Below the menu bar are buttons for "Ajouter un chassis", "Supprimer chassis", and "Offline".

The main interface shows a configuration for a "VXI_1" chassis. The "Chassis : 1" section includes buttons for "Ajouter module", "Supprimer module", "Déplacer module", and "Changer CPU". The "Module" list shows "_INSPECTION_", "GAMER_1_4", "ADC", "ADC2", and "MASTER_CENTRUM". The "MASTER_CENTRUM" module is selected, and its configuration is shown in the "Interface Utilisateur" tab.

The configuration table for the "MASTER_CENTRUM" module is as follows:

	TX1	TX2	TX3	TX4	TX5	TX6	TX7
RX	MUST II	VAMOS	EXOGAM	TIARA			
Maître	ON	ON	ON	ON	OFF	OFF	OFF
Mode	Correlé	Correlé	Correlé	Correlé	Seul	Seul	Seul
Local	ON	OFF	OFF	OFF	OFF	OFF	OFF
Envoyé...	Si touché	Si touché	Si touché	Si touché	Si touché	Si touché	Si touché
Retard du TAG	0 ns	0 ns	0 ns	0 ns	0 ns	0 ns	0 ns

Below the configuration table is a diagram titled "Horloge Universelle". It shows a clock icon with a "Pré-chargement" button above it and a "Raz Horloge" button below it. The diagram is connected to "Entrée Horloge en face avant" and "Signal VXIGO".

At the bottom of the interface, there are buttons for "Expert", "Label", and "Réservé". The status bar at the very bottom shows "Modifié jeudi 8 novembre 2007 11:11:01 MASTER_CENTRUM : Ajouter module < gamer.das >".

**Quad correlated DAQ in common dead time using the event number
(Time stamping available)**

Today GANIL DAQ

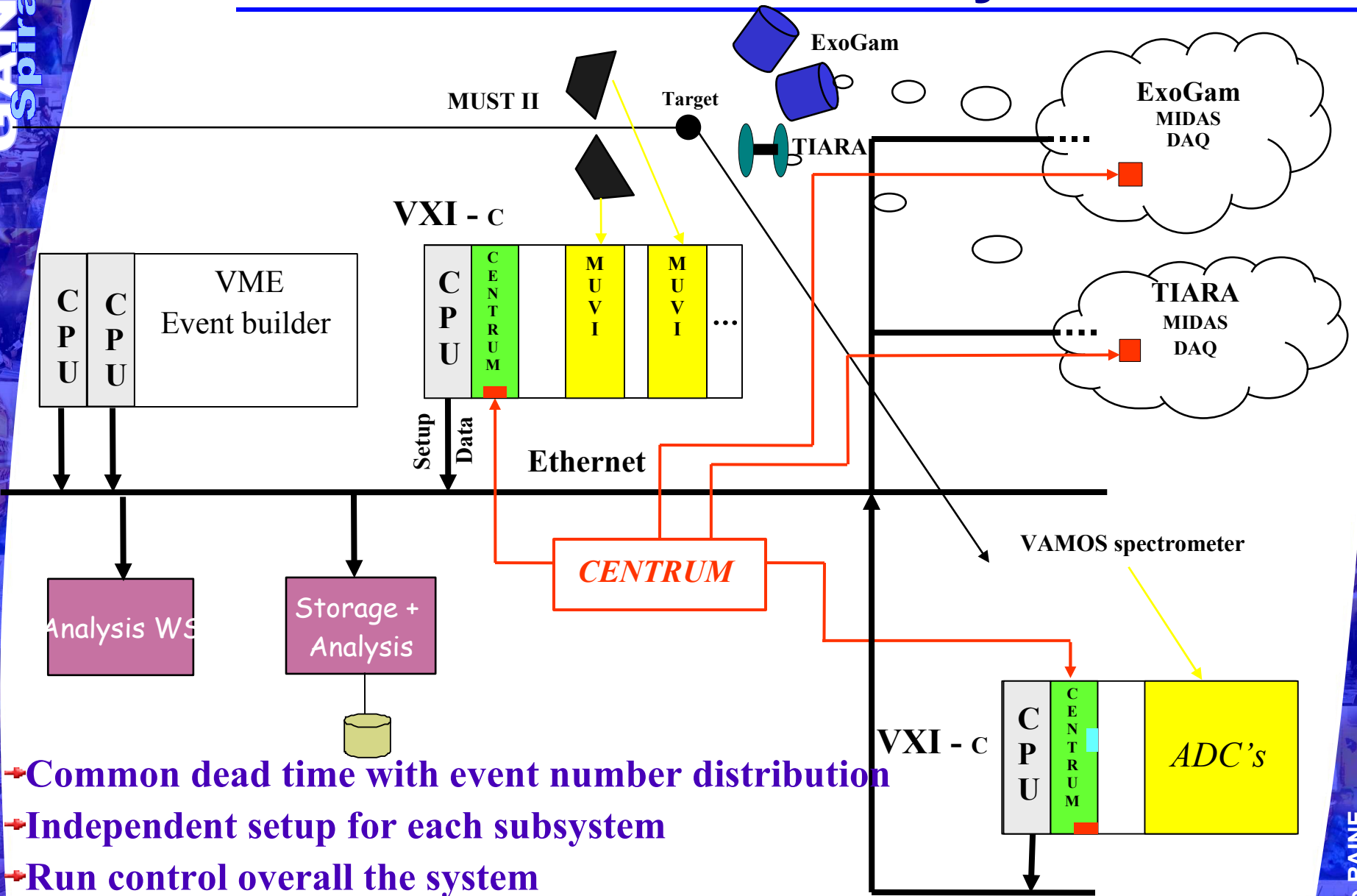

- Common dead time with event number distribution
- Independent setup for each subsystem
- Run control overall the system
- selection of active detector, start, stop, status, monitor data rate

Future GANIL DAQ

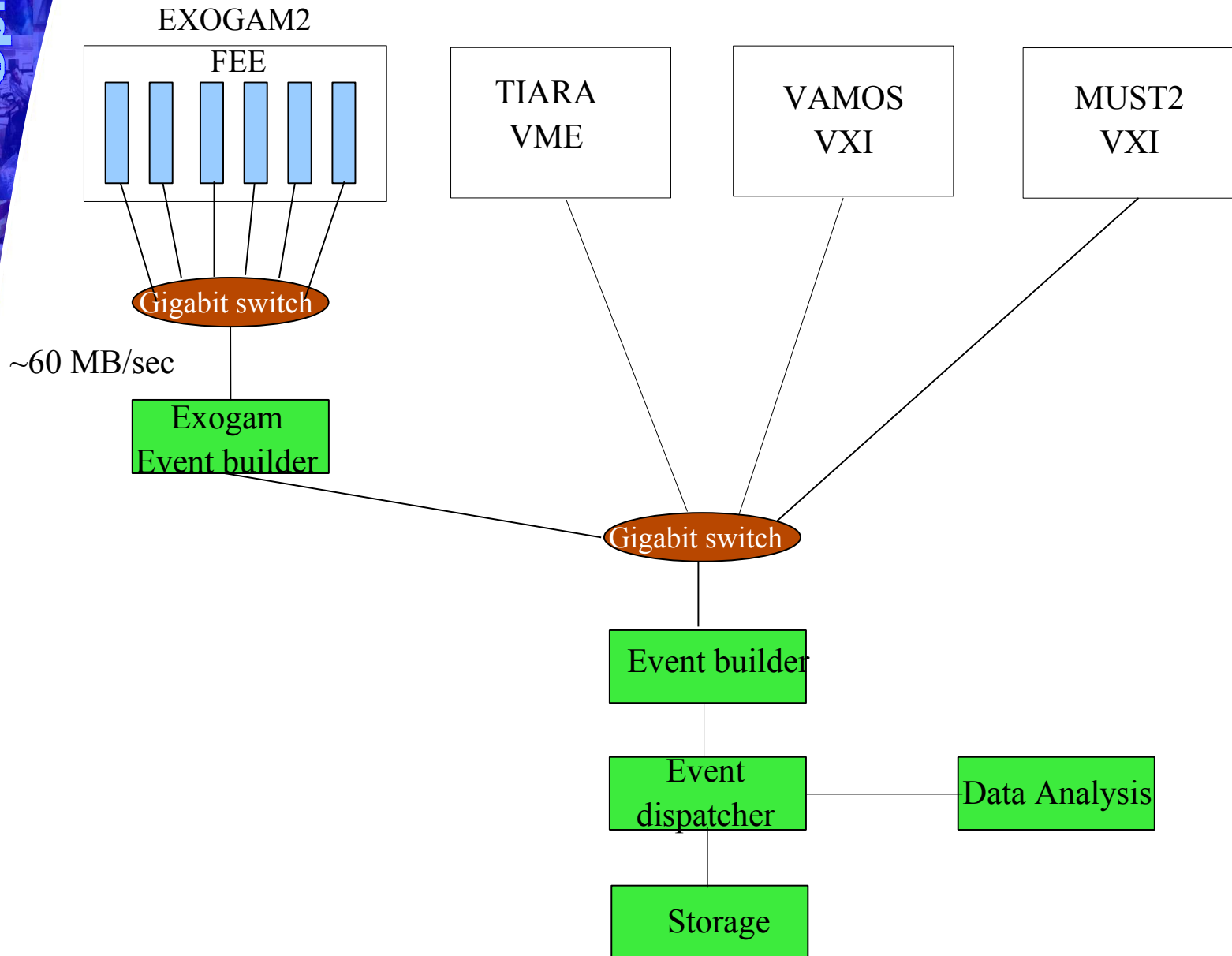

■ Requirements

- ◆ small scale to large scale experiments
- ◆ connect any frontend
- ◆ trigger or triggerless systems
- ◆ process time stamp data streams
- ◆ provide interfaces to plugin event filter codes
- ◆ highly modular acquisition system
- ◆ run control for all the components
- ◆ user friendly graphical interface
- ◆ High data rates to be defined (100MBytes/sec, 1GBytes/sec?)

Main components

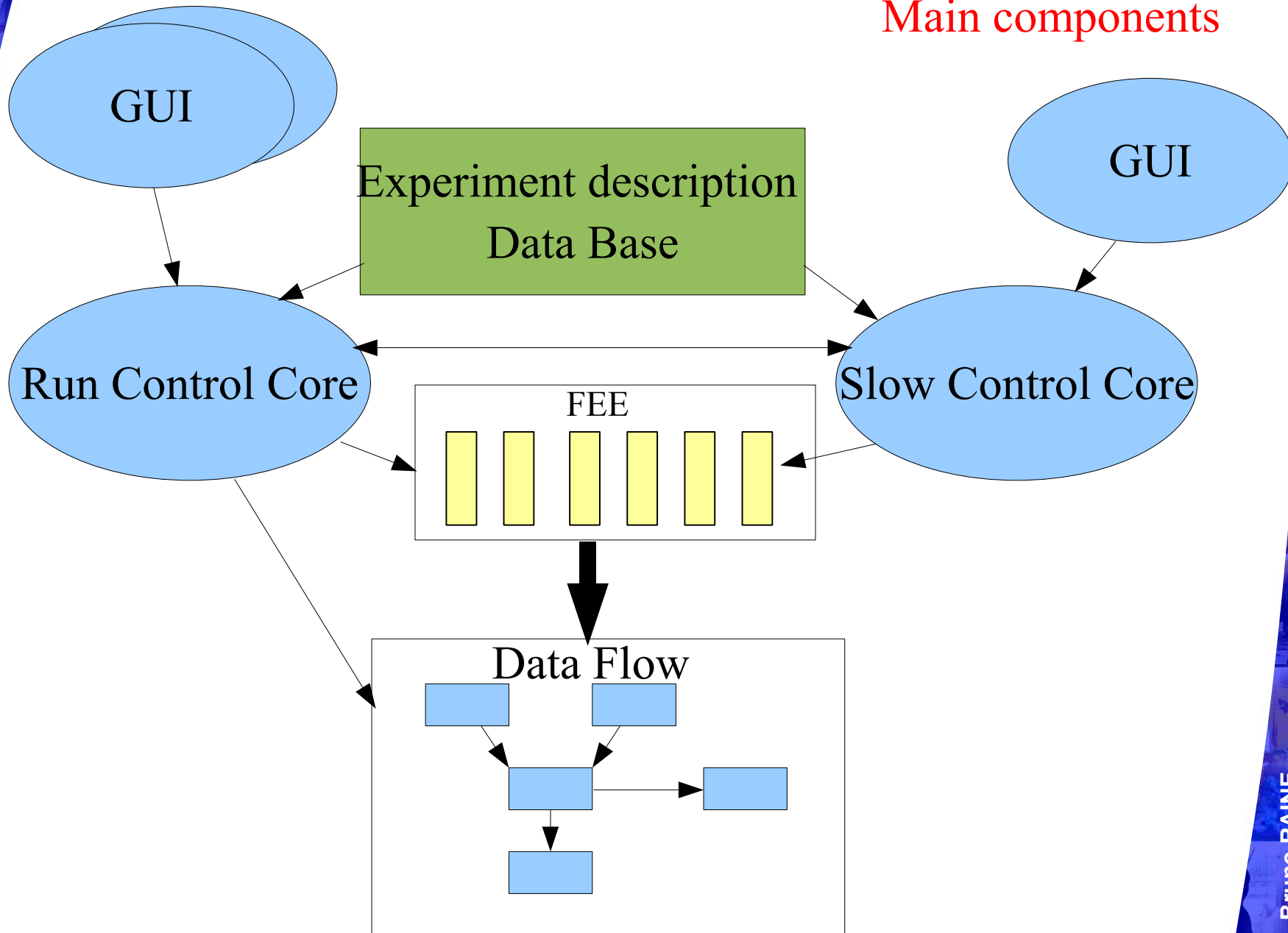

■ Some principles

- ◆ Linux used on most nodes (even in FPGA)
- ◆ Client/server architecture for Core of applications (eg Run control, Slow control)
- ◆ Configurations saved in XML
- ◆ Communications : SOAP messages
- ◆ Errors : Log4j, Log4C++, ...

■ Main tasks

- ◆ Describe hardware configuration
- ◆ Save / restore hardware configurations
- ◆ Setup electronics
- ◆ Monitor electronics
- ◆ Handle errors and pass them to run control
- ◆ Accept commands from outside (eg Run Control)
- ◆ Several occurrences of GUI

■ Current GANIL slow control

- ◆ GUI well adapted to current configurations
- ◆ To be redefined to separate GUI from kernel
- ◆ Save format to be upgraded to use XML
- ◆ **Work to be evaluated**

- **Main tasks**
 - ◆ **Configure DAQ for a run by selecting active components**
 - ◆ **Save/restore a configuration**
 - ◆ **Minimum set of commands to control all the components of the system (setup, start, stop...)**
 - ◆ **Monitor DAQ (status, data rate...)**
 - ◆ **Handle error messages**
 - ◆ **Log book**
 - ◆ **Scalable**
- **Needs a description of architecture of the DAQ**
- **Development started**

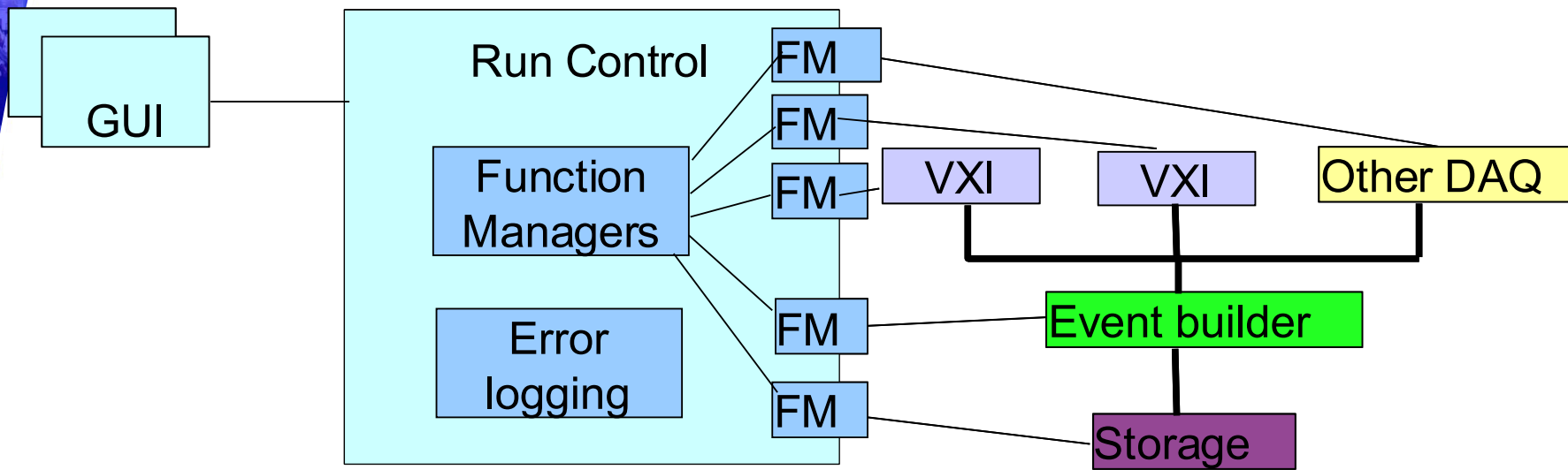

- **Run Control accesses equipments through specific Function Managers (FM) modules for**
 - ◆ **Monitoring**
 - ◆ **Elementary commands (init, start, stop...)**

■ NARVAL

- ◆ Developed by IPN Orsay and CSNSM
- ◆ Distributed Acquisition System
- ◆ Developed in Ada95
 - ✦ OO programming
 - ✦ Strongly typed language
 - ✦ Robust applications
 - ✦ Distributed processes by using Annex E (CORBA equivalent)
- ◆ Easy to link with C++
- ◆ Used for AGATA DAQ
- ◆ Collaboration with GANIL and LPC CAEN
- ◆ Web site : <http://narval.in2p3.fr/>

- ◆ **Main components**
 - ✦ **A main process to handle all configuration state (Coordinator)**
 - ✦ **Set of actors to manage dataflow**
 - **Producer : input of data flow (hardware or other DAQ)**
 - **Intermediary which acts as a NxM soft switch (event builder, data filter,...)**
 - **Consumer : end of data flow (data storage, output to other DAQ,...)**
 - ✦ **Error handler (Log4Ada)**
- ◆ **Data flow transport over Unix fifo, TCP/IP, Infiniband**
- ◆ **Communication via Web Services (SOAP) with the « Coordinator »**

NARVAL in GANIL DAQ Configuration under test

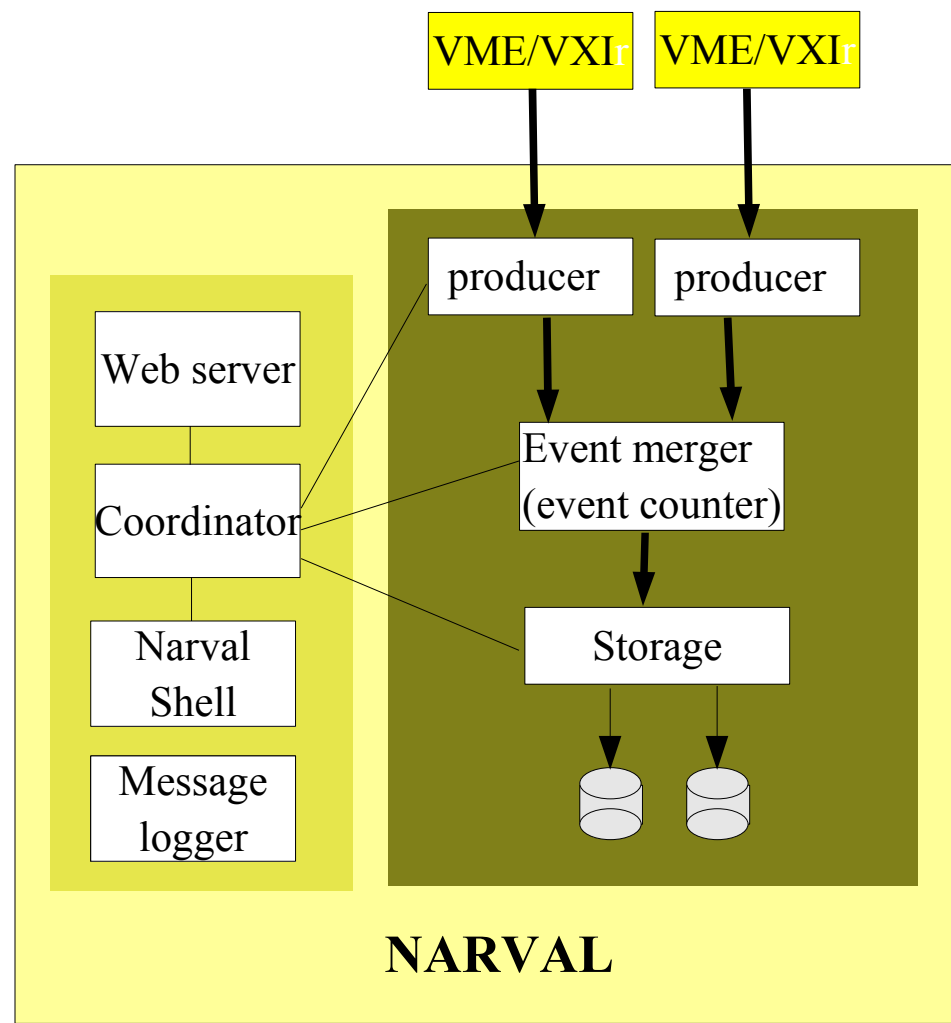

GANIL ROOT Utilities

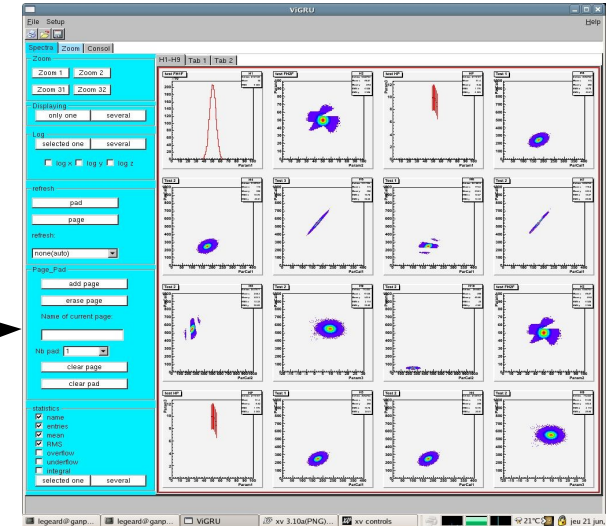
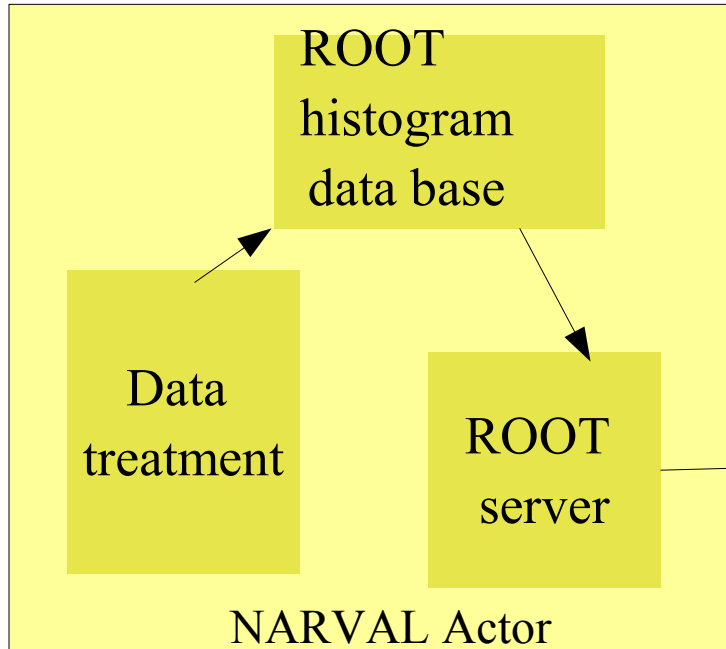

ViGRU
ROOT Spectra display

- ✓ ADA binding for basic commands to create, destroy, increment histograms
- ✓ ROOT library directly accessible for C++ programmers

NARVAL in GANIL DAQ

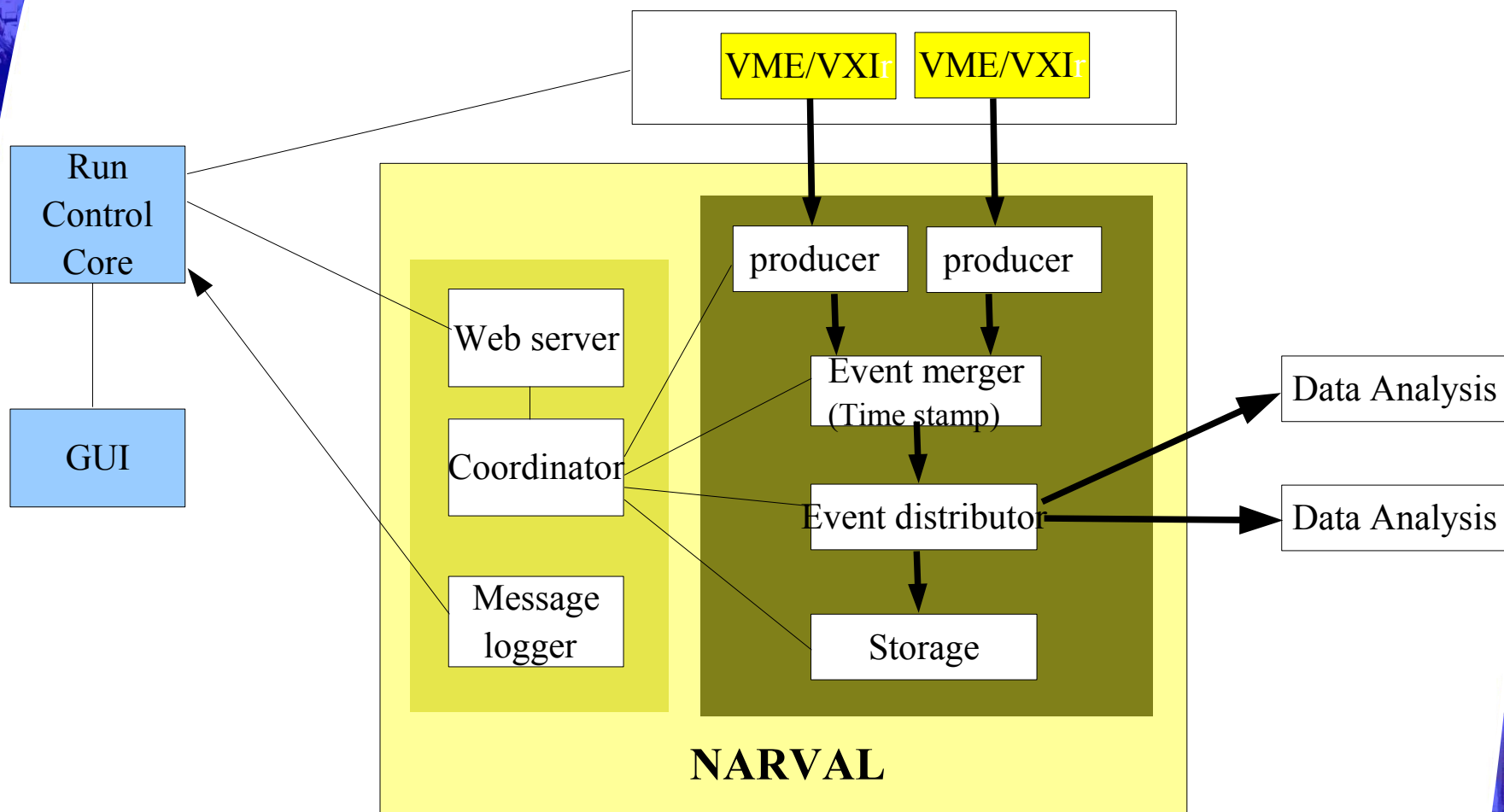

- **Web site : <http://narval.in2p3.fr/>**
 - ◆ **Configure scripts to install Narval**
 - ◆ **Stub Actor Generator for Ada programmer**
 - ◆ **Generic Actors for C, C++ programmer**
 - ◆ **Spectrum server based on Root in Narval Actors**