



The SHARAQ spectrometer

Tomohiro Uesaka
CNS, University of Tokyo

S. Shimoura, H. Sakai, S. Michimasa T. Kawabata, A. Saito,
K. Nakanishi, Y. Sasamoto,
(University of Tokyo)

T. Kubo, Y. Yanagisawa
(RIKEN Nishina Center)

G.P.Berg
(Notre Dame)



SHARAQ Spectrometer

SHARAQ is a high resolution magnetic spectrometer under construction at the RIBF.

University of Tokyo - RIKEN collaboration

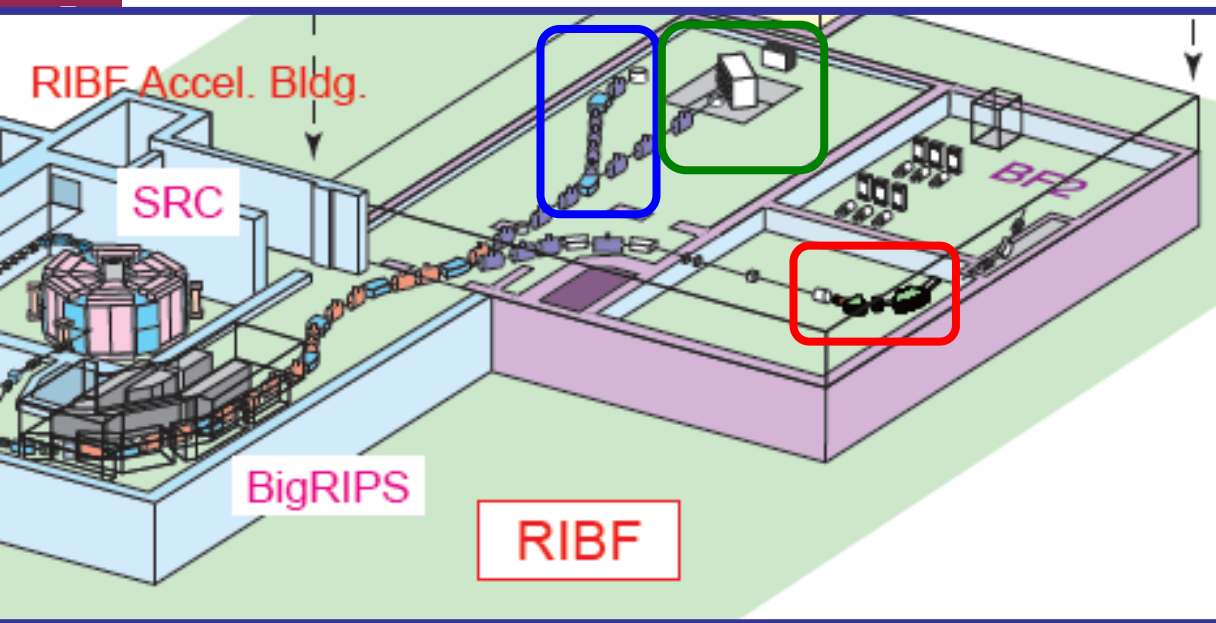

- Spectrometers at RIBF**
- ZeroDegree spectrometer**
multi-purpose
completed in 2007
 - SAMURAI spectrometer**
large acceptance
multi-particle detection
completed in 2012
 - SHARAQ spectrometer**
high resolution
finite angle meas.
completed in 2009

Current status of RIBF → Ohnishi

Scientific Opportunities with SHARAQ

- Nuclear structure in the vicinity of drip lines**
 correlation in (extremely) neutron/proton rich systems
 ex. tetra-neutron/superheavy hydrogen
 change of in-medium interaction depending on N/Z ratio
 ex. (\vec{p}, pN) reactions \rightarrow spin-orbit splitting
- High resolution analysis of reaction products by SHARAQ
 should greatly enhance experimental opportunities,
 especially when combined with γ and/or recoil/decay
 particle detectors.
- New spin-isospin excitation modes in nuclei**
 by use of RI-beam induced reactions as probes to nuclei
 ex. isovector spin-monopole resonances (IVSMR)
 double Gamow-Teller resonances (DGTR)
 ex. ($^{12}\text{N}, ^{12}\text{C}$) reaction
- Reaction mechanism of weakly-bound nuclei**
 elastic/inelastic scattering of halo/skin nuclei

Required Resolutions

Energy resolution

$\Delta E \approx 500 \text{ keV}$ for $A=12$ $E/A=300 \text{ MeV}$ particle

$$0.5 \text{ MeV} / (300 \times 12) \text{ MeV} = 1.3 \times 10^{-4}$$

→ corresponds to momentum resolution of $p/\Delta p \sim 15000$

Angular resolution □□ momentum transfer resolution

crucial in experiments with heavy ion beams,

where momentum of beam particle is huge

ex. ^{12}N , $300 \text{ MeV}/A$ $9 \text{ GeV}/c$

CRITERION: $\Delta q < 0.1 \text{ fm}^{-1}$

$$\Delta q \approx p(\text{beam}) \times \Delta\theta$$

$$\rightarrow \Delta\theta < 2 \text{ mrad}$$

$$\Delta\theta = 1 \text{ mrad}$$

Maximum rigidity

6.8 Tm

Momentum resolution

$dp/p = 1/14700$

Angular resolution

~ 1 mrad

Momentum acceptance

$\pm 1\%$

Angular acceptance

~ 5 msr

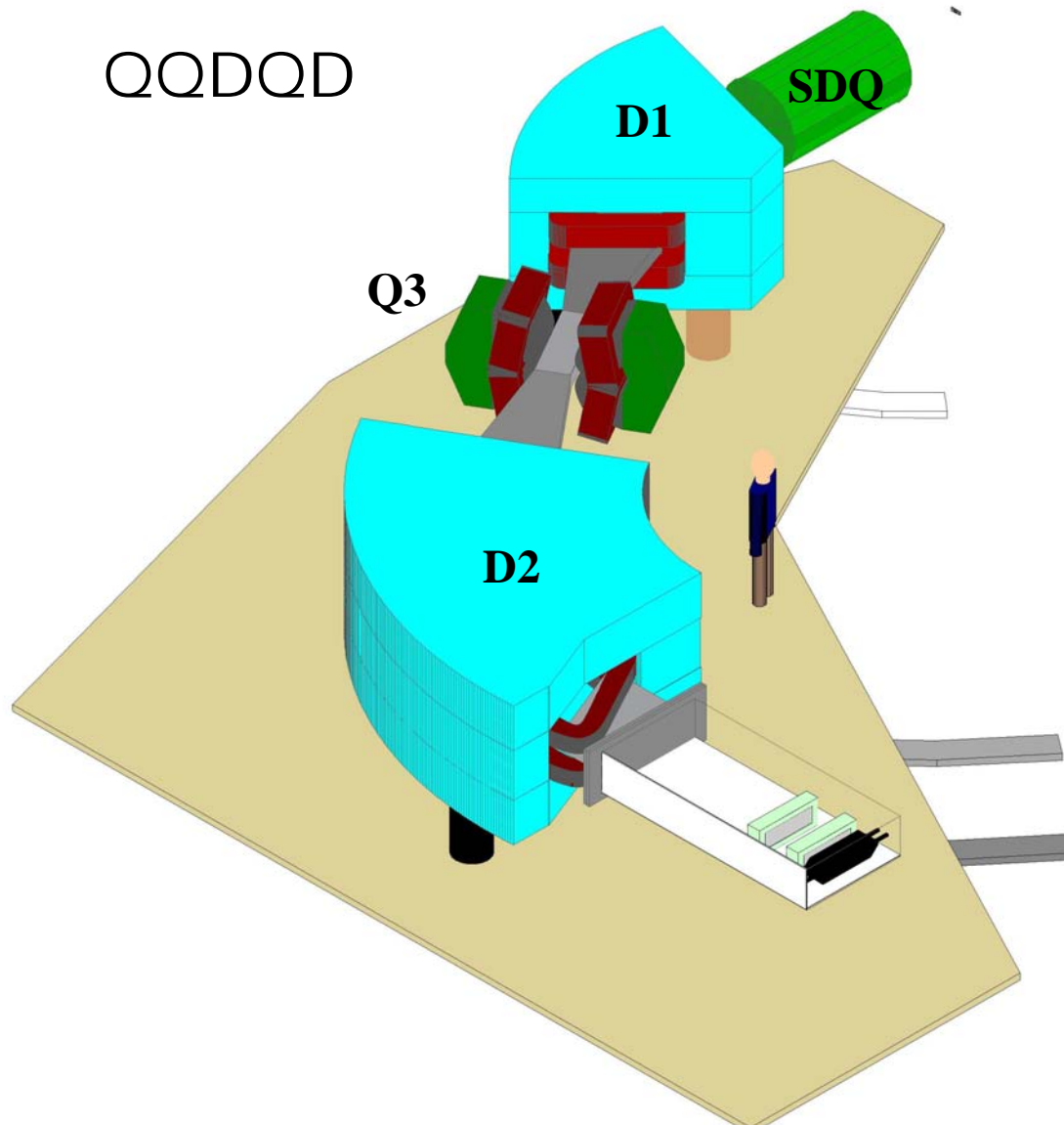

Specifications

dispersion (D)	5.86 m
horizontal magnification (M_x)	0.40
D/M_x	14.7 m
momentum resolution (image size 1mm)	1/14700
vertical magnification (M_y)	0.0
angular resolution	< 1 mrad
vertical acceptance	± 3deg

for spot size 60mm \times 10mm (in dispersion matching operation)

horizontal acceptance	± 1deg
solid angle	2.7msr

for spot size of 10mm \times 10mm

solid angle	4.8 msr
--------------------	----------------

1st order matrix & Req. for FP detectors

$$\begin{pmatrix}
 \boxed{-0.3974} & -0.0000 & 0.0000 & 0.0000 & 0.0000 & -5.8582 \\
 -0.7727 & \boxed{-2.5164} & 0.0000 & 0.0000 & 0.0000 & 0.6608 \\
 0.0000 & 0.0000 & \boxed{-0.0000} & \boxed{-2.3039} & 0.0000 & 0.0000 \\
 0.0000 & 0.0000 & 0.4340 & -0.1971 & 0.0000 & 0.0000 \\
 -0.2948 & -0.9073 & 0.0000 & 0.0000 & 1.0000 & -0.0279 \\
 0.0000 & 0.0000 & 0.0000 & 0.0000 & 0.0000 & 1.0000
 \end{pmatrix}$$

Small horizontal magnification of 0.4

→ Δx of FP detectors should be < 0.4 mm

(image size of 1 mm is assumed)

Angular magnification in horizontal plane of 2.5

Existing technology is O.K for the FP detector.

CRDC is being made under UT-GANIL collaboration

→ Michimasa's talk

Requirement for Δy is more or less relaxed, $\sim 1-2$ mm.

High-resolution beamline for SHARAQ

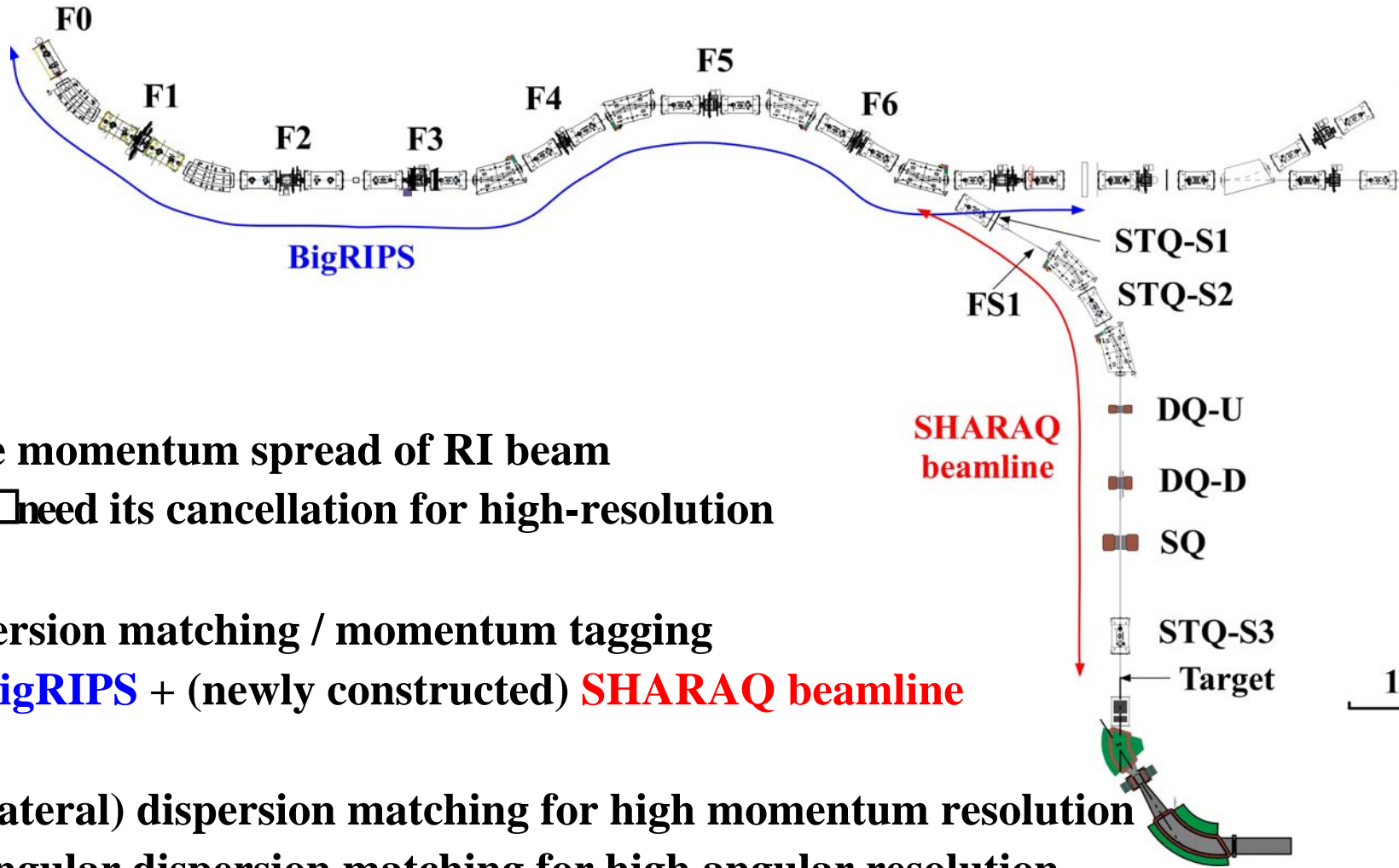

large momentum spread of RI beam

→ need its cancellation for high-resolution

dispersion matching / momentum tagging

BigRIPS + (newly constructed) **SHARAQ beamline**

(lateral) dispersion matching for high momentum resolution

angular dispersion matching for high angular resolution

Dispersion matched transport

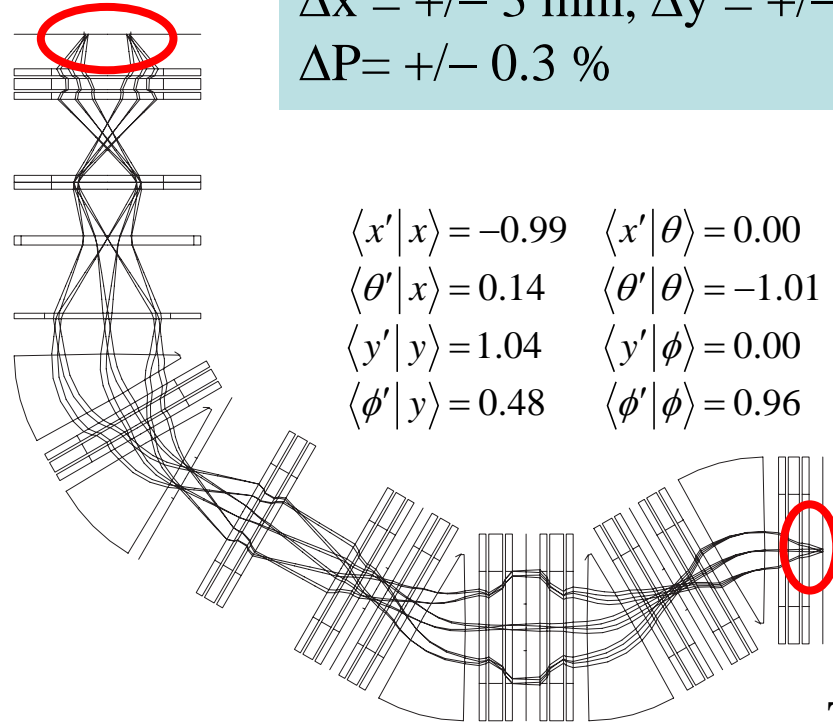
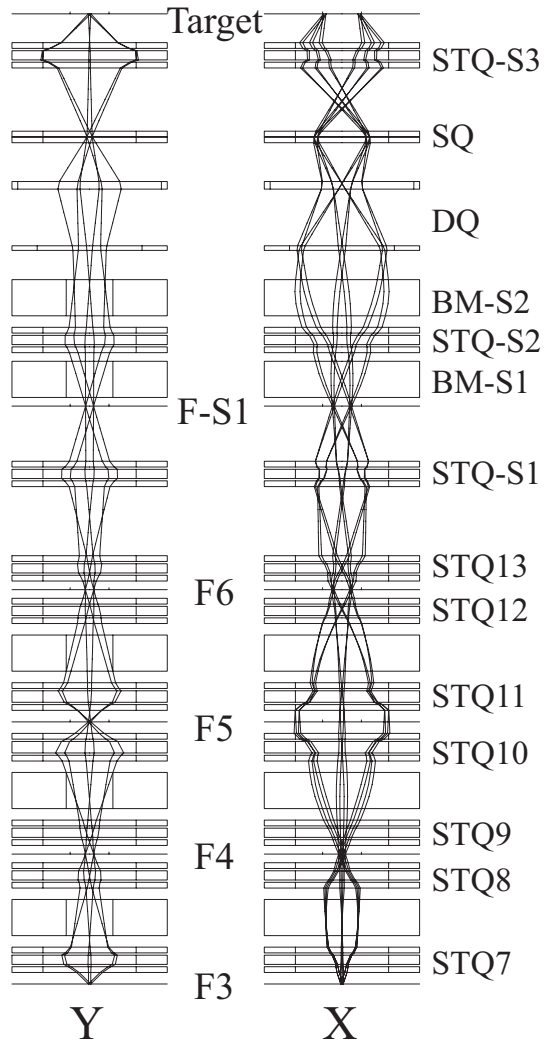

$$\Delta\theta_x = \pm 10 \text{ mr}, \Delta\theta_y = \pm 30 \text{ mr},$$

$$\Delta x = \pm 3 \text{ mm}, \Delta y = \pm 3 \text{ mm},$$

$$\Delta P = \pm 0.3 \%$$

$\langle x' x \rangle = -0.99$	$\langle x' \theta \rangle = 0.00$	$\langle x' \delta \rangle = -14.76$
$\langle \theta' x \rangle = 0.14$	$\langle \theta' \theta \rangle = -1.01$	$\langle \theta' \delta \rangle = 4.79$
$\langle y' y \rangle = 1.04$	$\langle y' \phi \rangle = 0.00$	
$\langle \phi' y \rangle = 0.48$	$\langle \phi' \phi \rangle = 0.96$	

T. Kawabata

In the dispersion matched mode, trajectories at F3 and before the target are measured.

Achromatic Transport

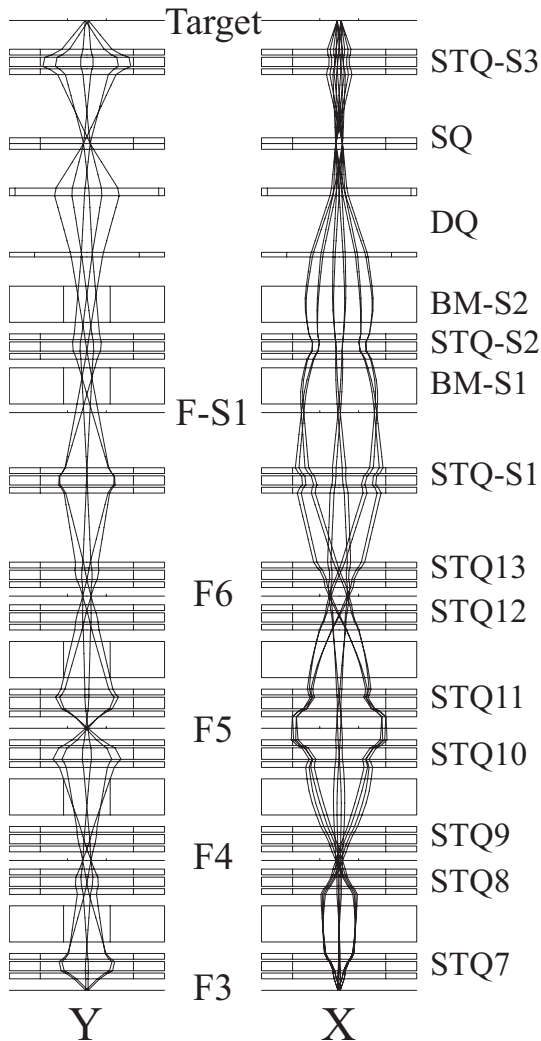

$$\Delta\theta_x = \pm 20 \text{ mr}, \Delta\theta_y = \pm 30 \text{ mr},$$

$$\Delta x = \pm 3 \text{ mm}, \Delta y = \pm 3 \text{ mm},$$

$$\Delta P = \pm 0.3 \%$$

$$\begin{aligned} \langle x' | x \rangle &= 1.60 & \langle x' | \theta \rangle &= 0.00 & \langle x' | \delta \rangle &= -0.00 \\ \langle \theta' | x \rangle &= -0.83 & \langle \theta' | \theta \rangle &= 0.63 & \langle \theta' | \delta \rangle &= -0.47 \\ \langle y' | y \rangle &= 1.38 & \langle y' | \phi \rangle &= 0.00 & & \\ \langle \phi' | y \rangle &= -0.78 & \langle \phi' | \phi \rangle &= 0.73 & & \end{aligned}$$

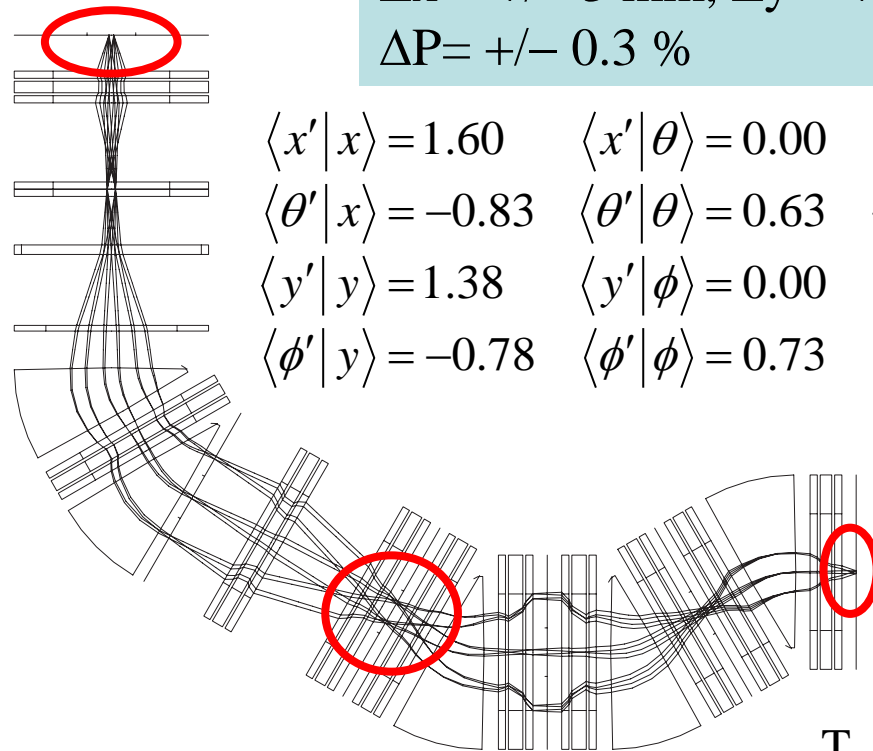

In the achromatic mode, trajectories at F6 are needed to be measured for momentum tagging.

Measurements of beam trajectory

In the case of achromatic transport

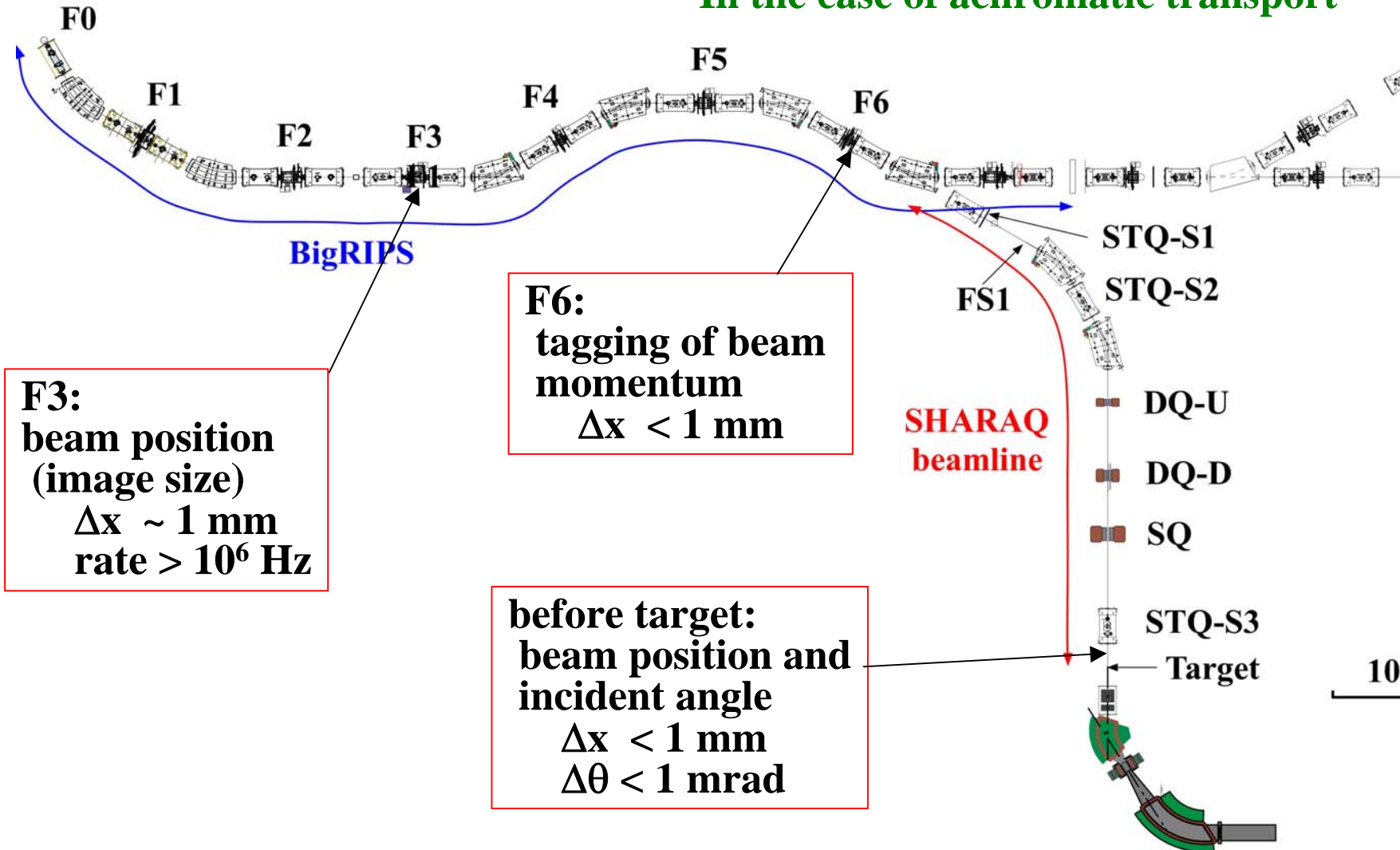

Requirements for beam-line detectors

- **should determine the beam trajectory with**
 - $\Delta x \sim 0.5 \text{ mm}$
 - $\Delta\theta < 1 \text{ mrad}$
- **should not spoil the energy/angular resolutions**
 - $\Delta E < 0.5 \text{ MeV}$
 - $\Delta\theta < 1 \text{ mrad}$
 - $Z < 10$: multiple scattering limits the detector thickness.**
 - $x/X_0 \sim 10^{-4}$
- **should work at $> 10^6$ particle/sec**

Low-pressure MWDC can be the solution.

→ **Michimasa (and Ozeki)**

works at a higher beam rate?

Target for high-resolution measurements

In many cases, target thickness is most critical.

ex. charge exchange reaction:

energy loss difference between projectile and ejectile.

For a better use of SHARAQ,

we need a “next generation TARGET system” such as an active target, or a multi-layered target with a sensitivity to reaction point.

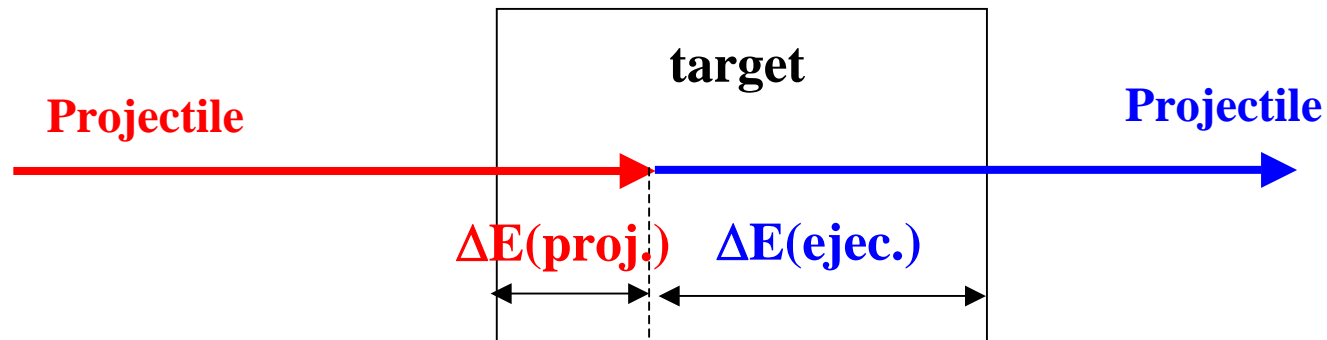

- **The high-resolution SHARAQ spectrometer is being constructed at RI beam factory by University of Tokyo, in collaboration with RIKEN.**
- **Demands for FP and beam-line detectors are presented.**
 - $\Delta x < 0.5 \text{ mm}$
 - $\Delta\theta < 1 \text{ mrad}$
 - **Michimasa's talk**
- **“Next generation detector/target system” will enhance the applicability of the spectrometer.**

- **Missing mass spectroscopy with RI beams**
 - spin-isospin excitation via RI-beam induced reaction
 - probe highly excited states of stable nuclei
 - with extremely small momentum transfer
 - ex. IVSMR, DGTR, tetra neutron spectroscopy
 - elastic scattering experiments

- **High resolution analysis of reaction products**
 - in inelastic, breakup, knockout reactions
 - combined with γ -ray and/or decay-particles measurements

- **and more**
 - model case: S800 @NSCL, MSU

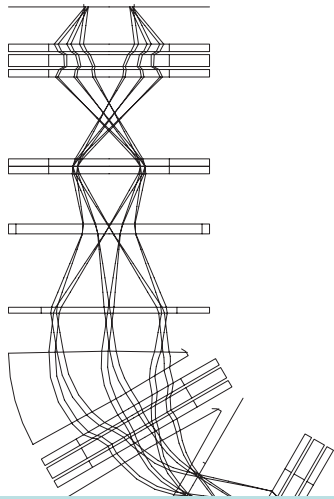

$\Delta\theta_x = \pm 10 \text{ mr}$, $\Delta\theta_y = \pm 30 \text{ mr}$,
 $\Delta x = \pm 3 \text{ mm}$, $\Delta y = \pm 3 \text{ mm}$,
 $\Delta P = \pm 0.3 \%$

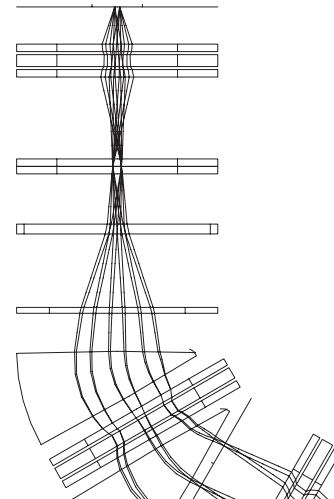

$\Delta\theta_x = \pm 20 \text{ mr}$, $\Delta\theta_y = \pm 30 \text{ mr}$,
 $\Delta x = \pm 3 \text{ mm}$, $\Delta y = \pm 3 \text{ mm}$,
 $\Delta P = \pm 0.3 \%$

Current Status & Schedule

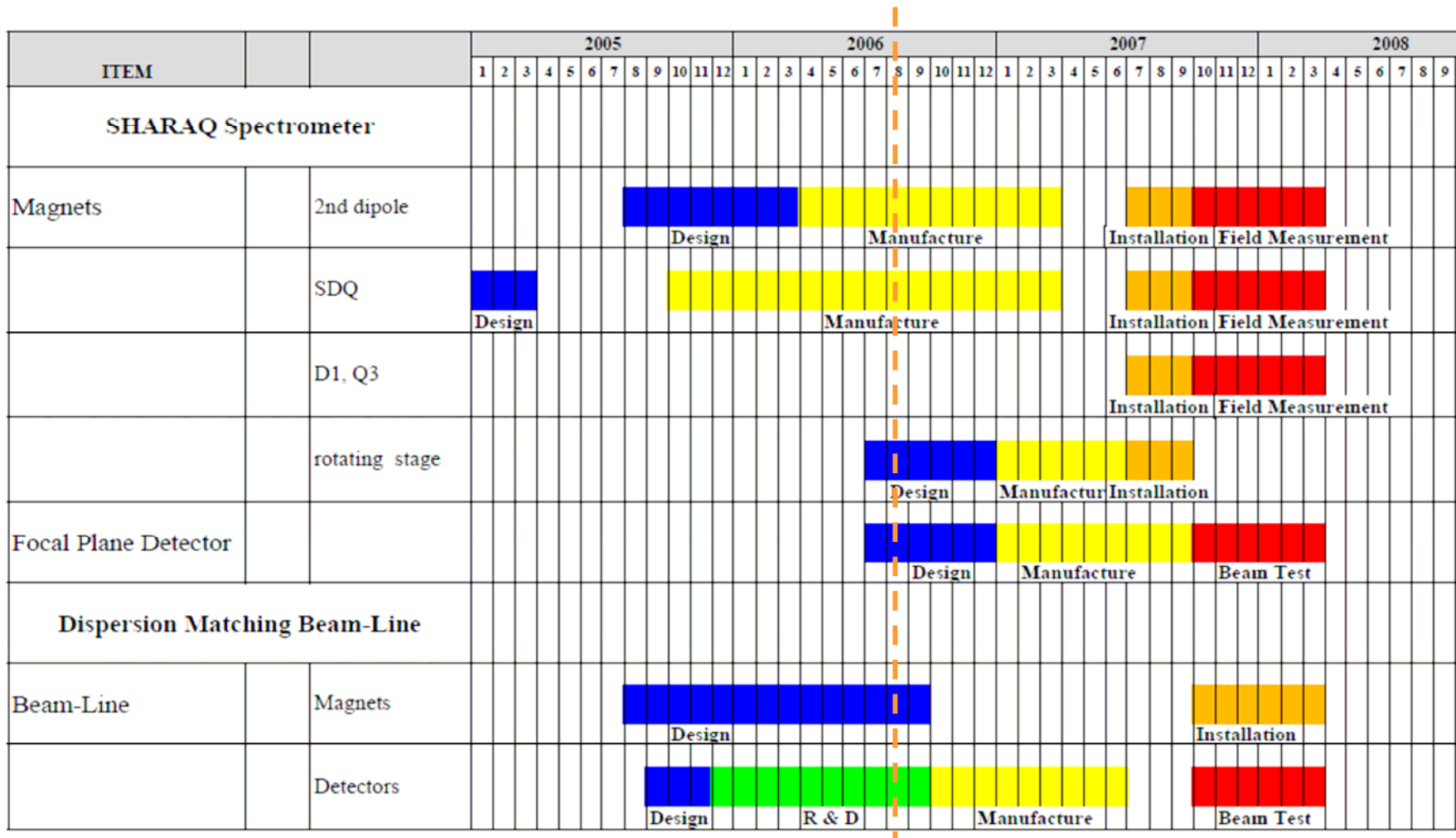

The high-resolution SHARAQ spectrometer is under construction and will be completed in 2008.

design of magnetic elements:	fixed
design of beamline:	fixed
development of detectors:	in progress

**Still there are much room to introduce your devices, ex.
for γ -ray and/or decay-particle detection.**

We are pleased to start collaboration for the BEST use of the spectrometer.

**contact person: S. Shimoura shimoura@cns.s.u-tokyo.ac.jp
T. Uesaka uesaka@cns.s.u-tokyo.ac.jp**