

**High-resolution experiments  
on nuclear reactions  
with relativistic heavy-ion beams**

An explorative study

# Layout

- **Nuclear-reaction schemes**
  - Beam energy and impact parameter
- **The fragment separator of GSI**
  - In-flight separator and energy-loss spectrometer
- **Experiments with separated secondary beams**
  - Fission channels
- **Production cross sections of individual nuclides**
  - Global features and nuclear-structure phenomena
- **High-precision experiments on longitudinal momentum**
  - Characterization of reaction channel, friction, re-acceleration, kinematics of multifragmentation

# Reactions classified by beam energy and impact parameter

## Beam energy:

Fermi spheres  
of projectile and  
target:

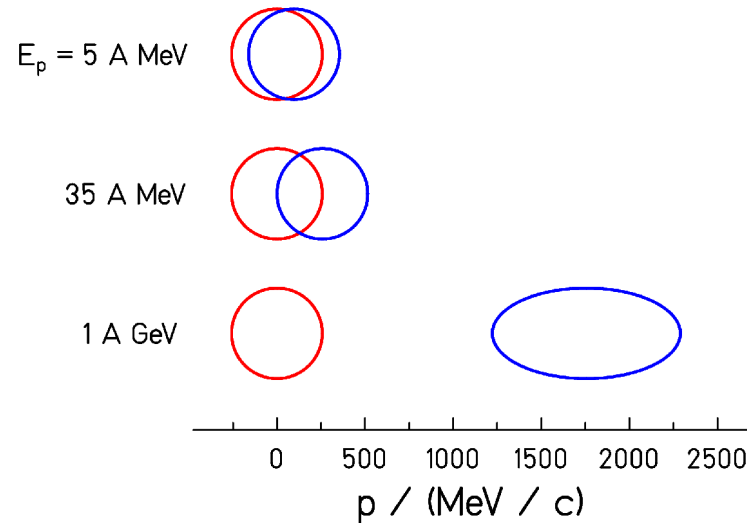

Coulomb barrier: Nucleons stay  
inside a common potential:

**Dominance of fusion**

SIS-energies: Scattering of quasi-  
free nucleons:

**Participant – spectator picture**

## Impact parameter range:

$b > r_1 + r_2$ : No nuclear contact, only Coulomb excitation  $\rightarrow$  mostly GDR

$b$  slightly smaller than  $r_1 + r_2$ : Very peripheral collisions

$b < r_1 + r_2$ : Violent collisions, onset of multifragmentation

# Layout

- **Nuclear-reaction schemes**
  - Beam energy and impact parameter
- **The fragment separator of GSI**
  - In-flight separator and energy-loss spectrometer
- **Experiments with separated secondary beams**
  - Fission channels
- **Production cross sections of individual nuclides**
  - Global features and nuclear-structure phenomena
- **High-precision experiments on longitudinal momentum**
  - Characterization of reaction channel, friction, re-acceleration, kinematics of multifragmentation

# GSI installations

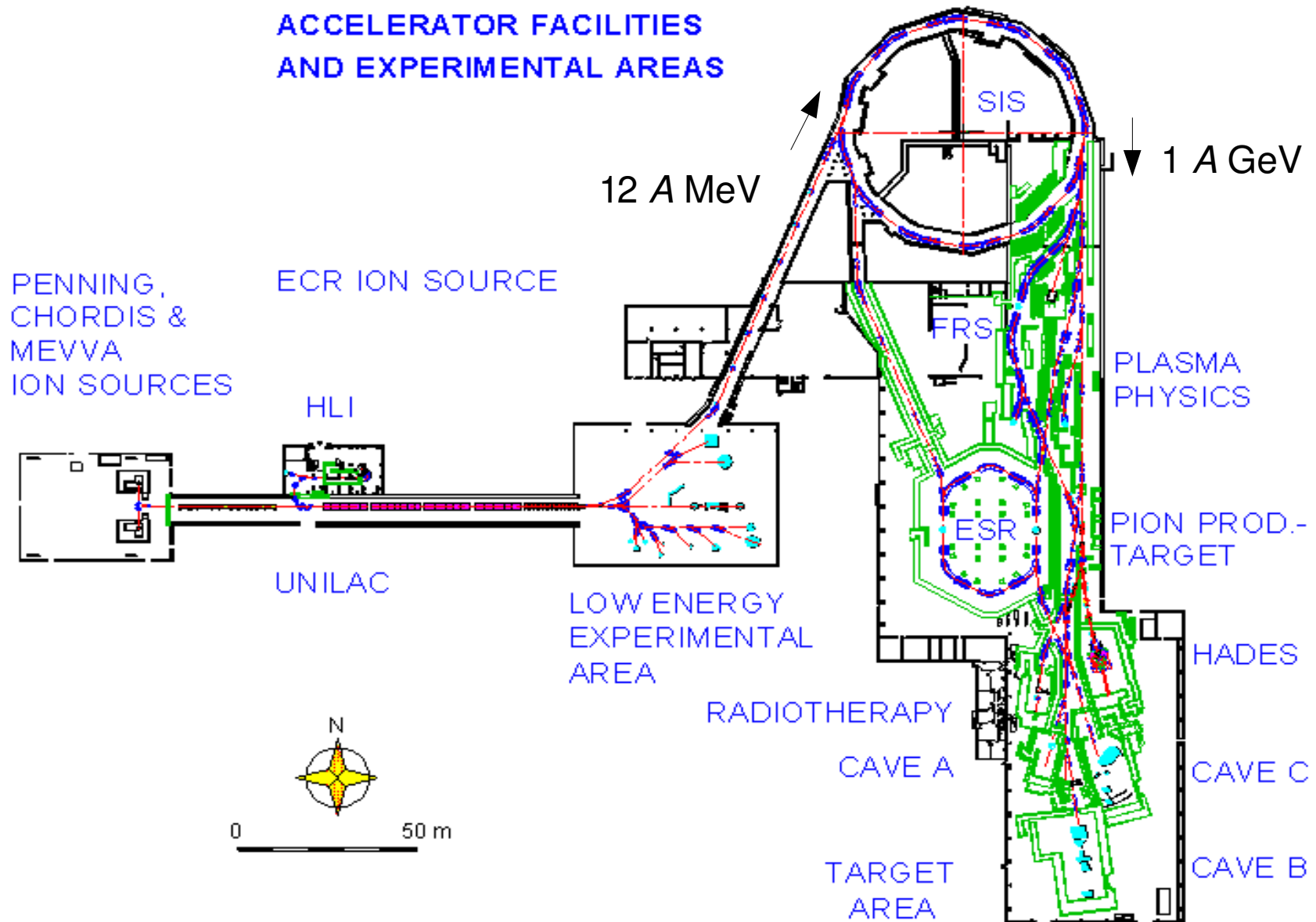

# The fragment separator

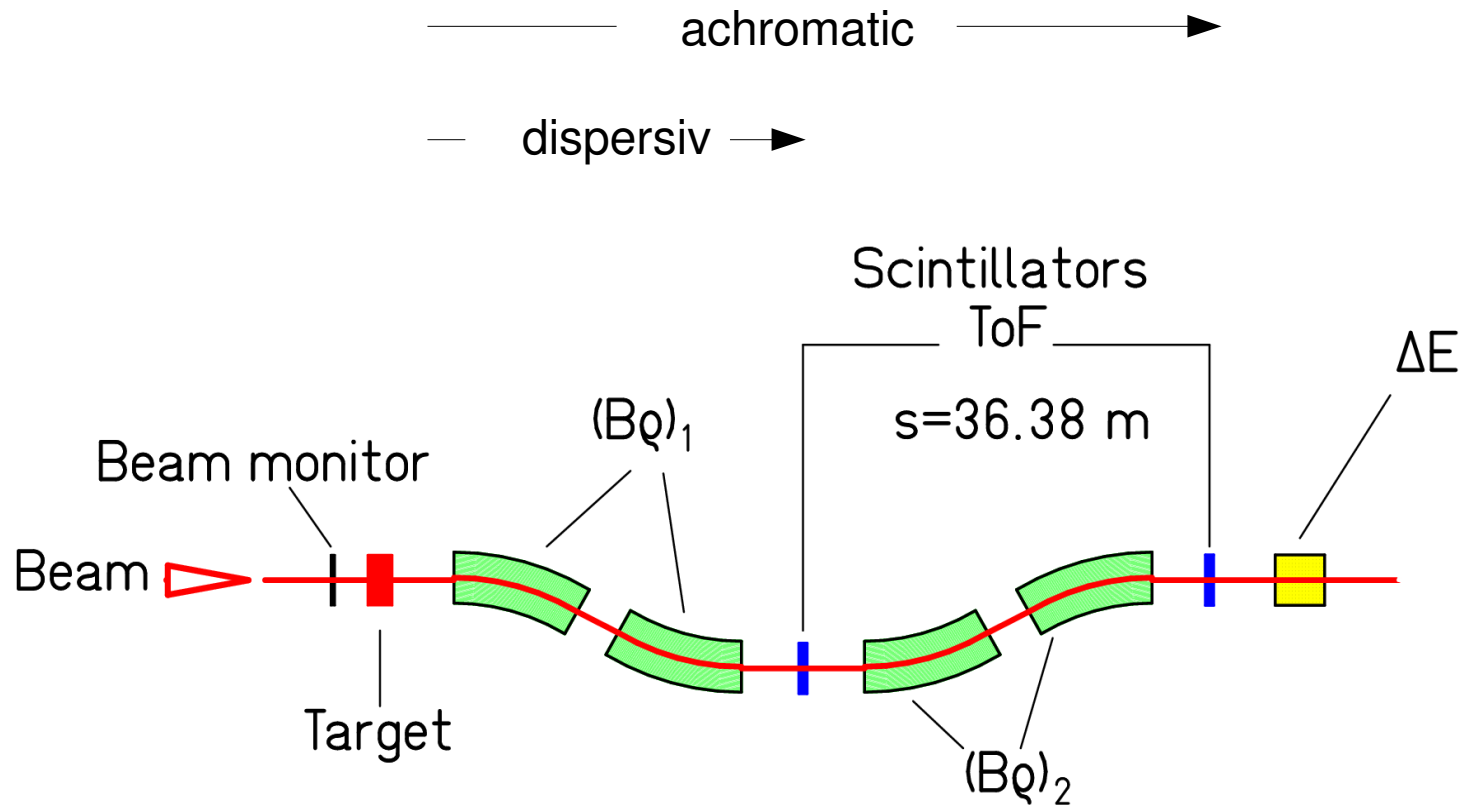

A large-scale “copy” of LISE

An in-flight separator for secondary beams (like LISE or SISSI + ALPHA)

A high-resolution energy-loss spectrometer (like SPEG)

# Layout

- **Nuclear-reaction schemes**
  - Beam energy and impact parameter
- **The fragment separator of GSI**
  - In-flight separator and energy-loss spectrometer
- **Experiments with separated secondary beams**
  - Fission channels
- **Production cross sections of individual nuclides**
  - Global features and nuclear-structure phenomena
- **High-precision experiments on longitudinal momentum**
  - Characterization of reaction channel, friction, re-acceleration, kinematics of multifragmentation

# Coulomb fission with secondary $^{238}\text{U}$ projectiles: experimental set-up

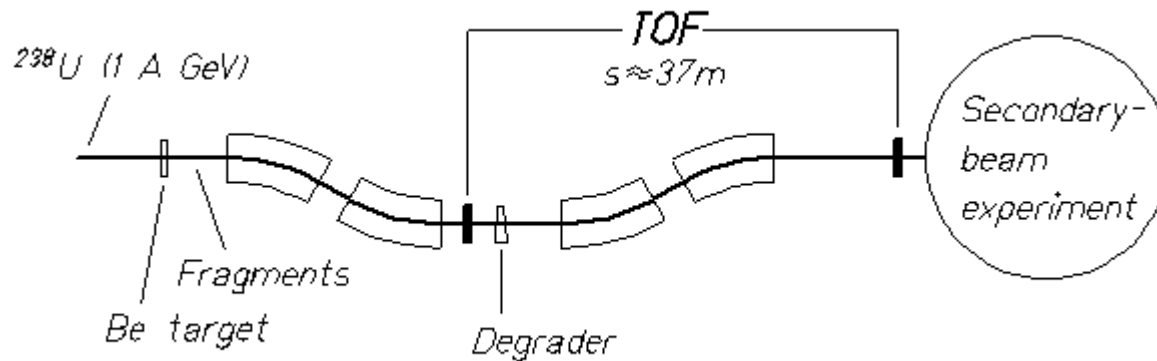

Separation of the secondary beams

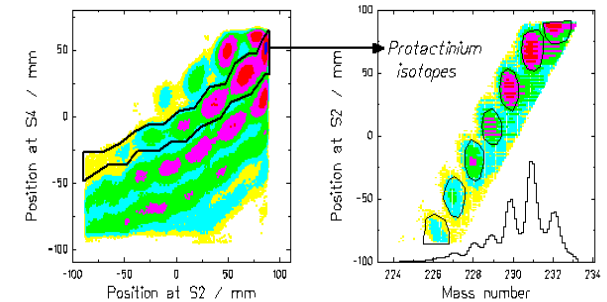

Measurement of  $Z_1$ ,  $Z_2$ , and kinetic energies  
(filter on Coulomb fission,  $b > r_1 + r_2$ )

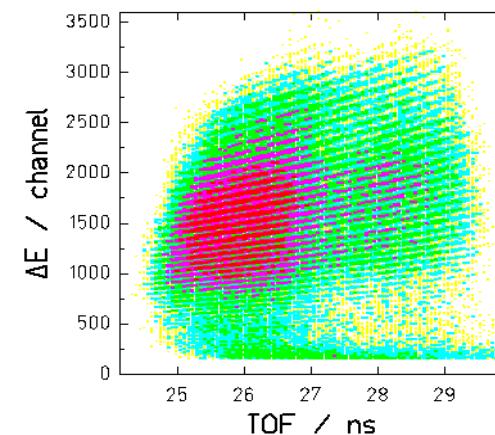
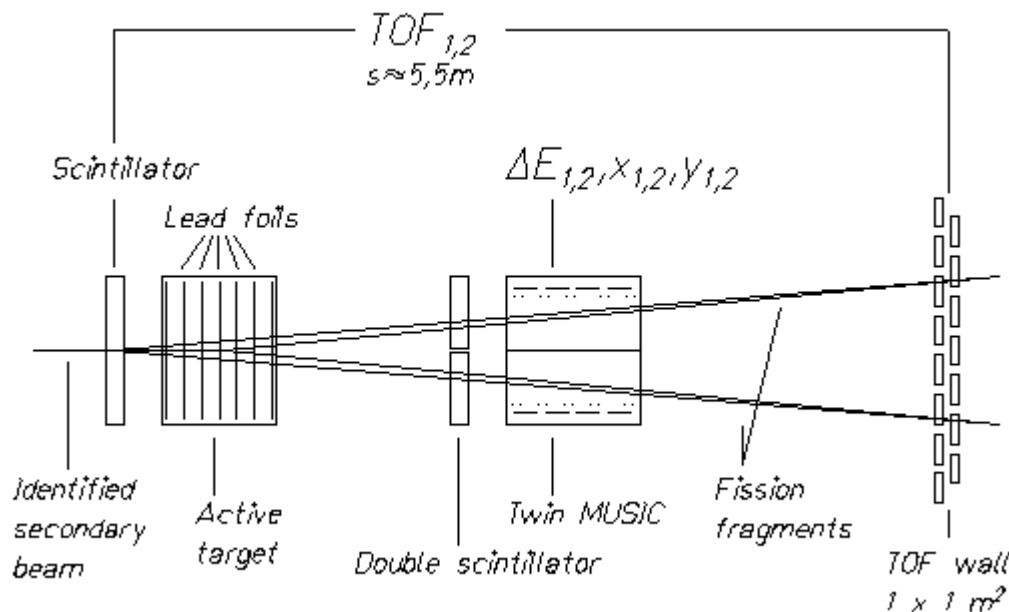

# Results on Z distributions in fission

✕ Coulomb fission  
of secondary  
projectiles

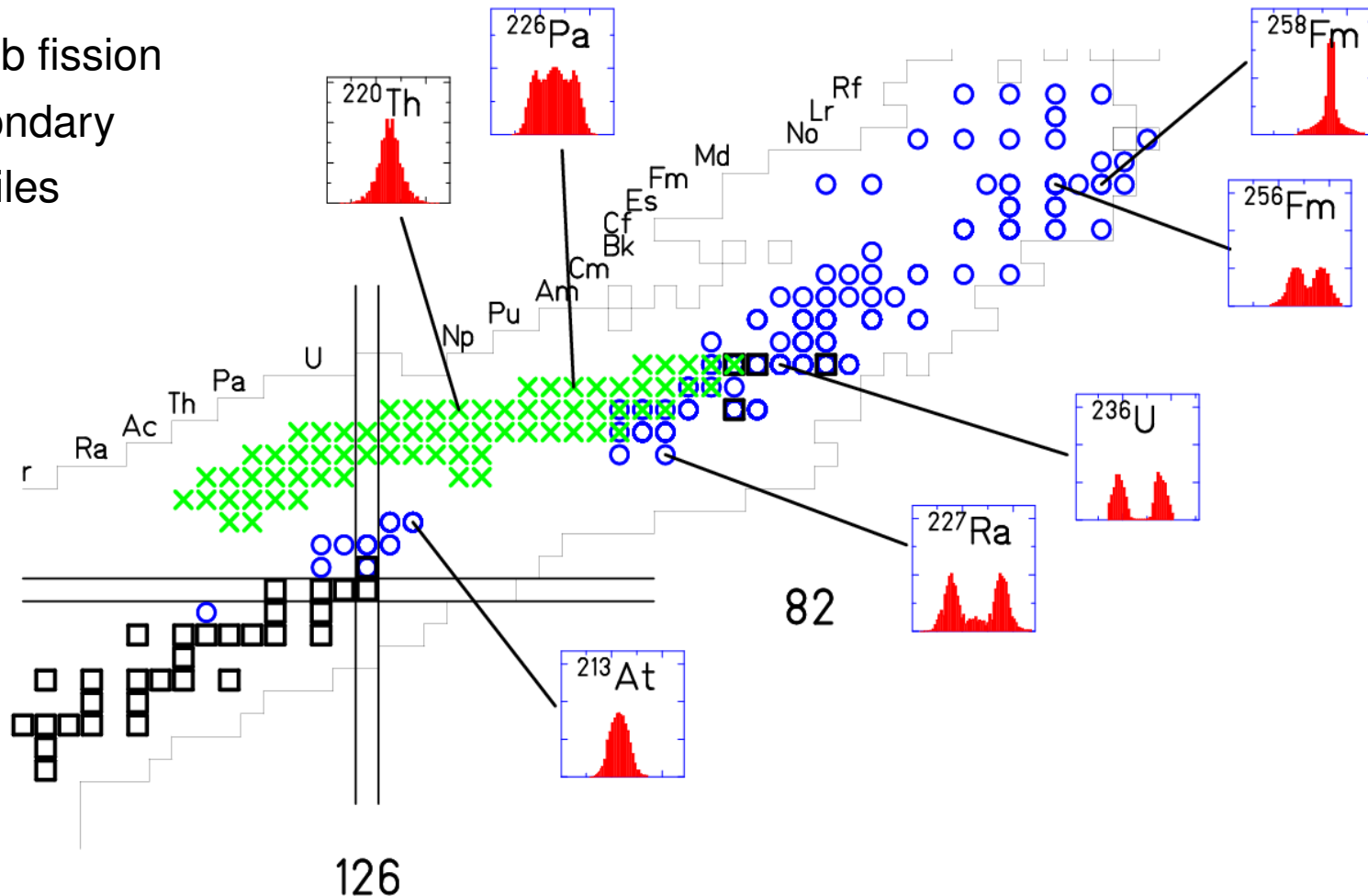

Extending the experimental knowledge in the region of neutron-deficient actinides.

# Parameters of fission channels

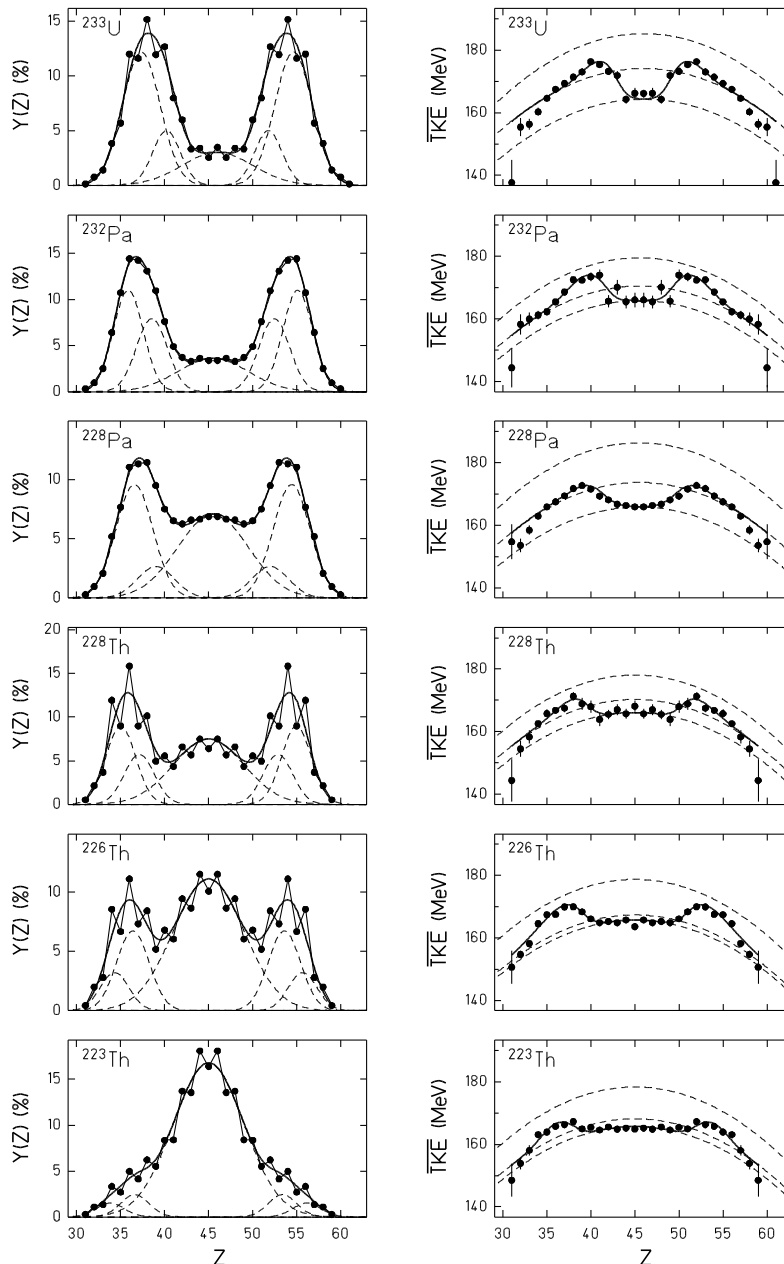

Good description with  
3 fission channels  
(different fission valleys: Brosa  
1990)

Parameters fitted to data.

Expected relation to fragment  
shells (Wilkins et al. 1976):

1. Standard 1: close to  $^{132}\text{Sn}$
2. Standard 2: near  $N = 86$
3. Super-long: at symmetry

# A surprising result

Well known gross feature of mass distributions:

Flynn et al, 1972

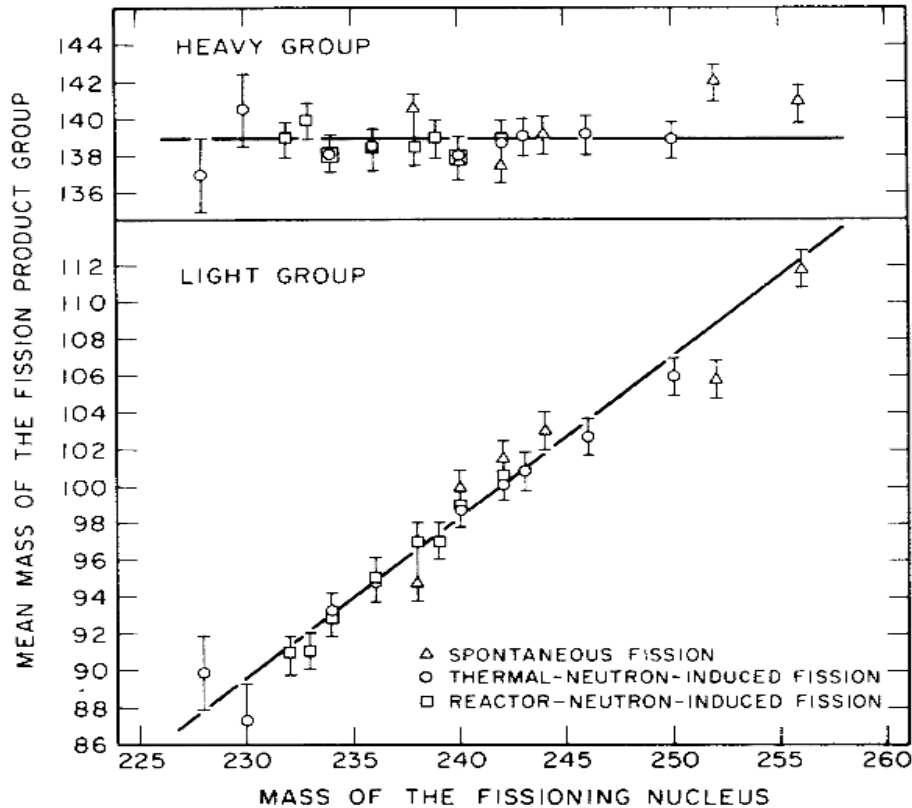

New analysis of all avail. exp. information

Böckstiegel et al., 2008

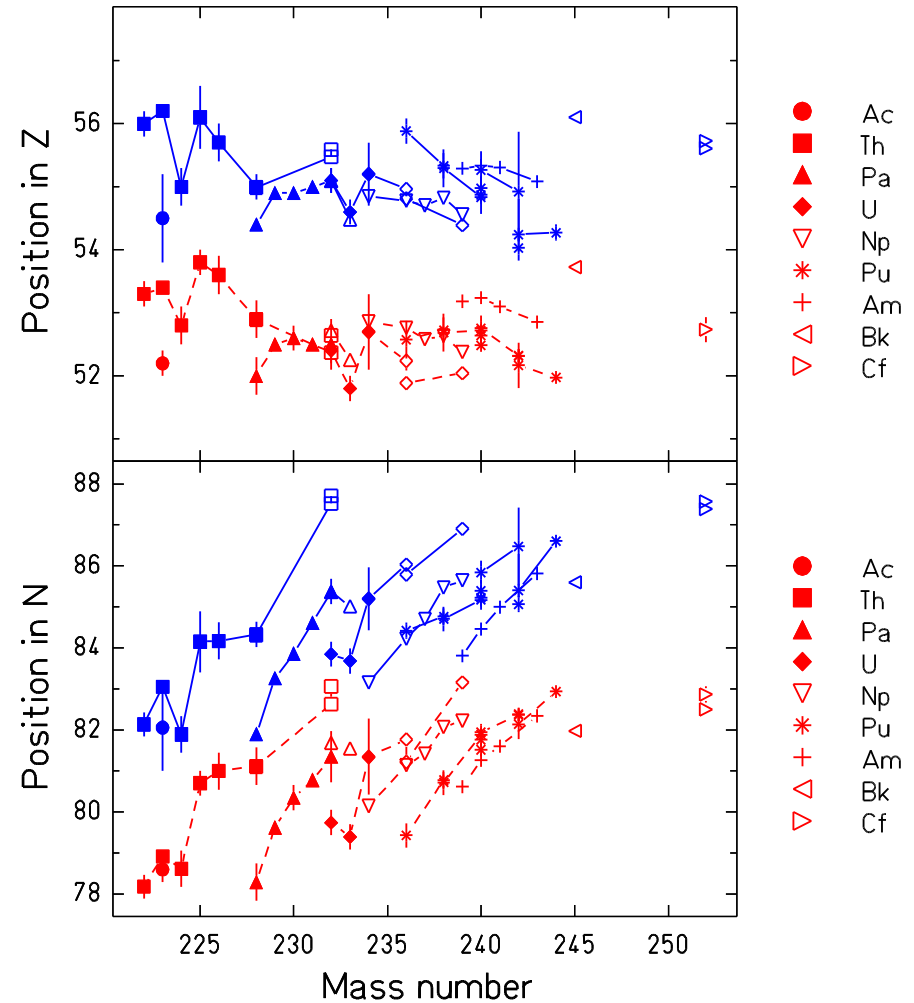

Asymmetric fission channels are constant in  $Z$  (!!!) (not in  $A$  or  $N$ ) in the heavy fragment.

**A challenge for theory.**

# Layout

- **Nuclear-reaction schemes**
  - Beam energy and impact parameter
- **The fragment separator of GSI**
  - In-flight separator and energy-loss spectrometer
- **Experiments with separated secondary beams**
  - Fission channels
- **Production cross sections of individual nuclides**
  - Global features and nuclear-structure phenomena
- **High-precision experiments on longitudinal momentum**
  - Characterization of reaction channel, friction, re-acceleration, kinematics of multifragmentation

# Identification of nuclides

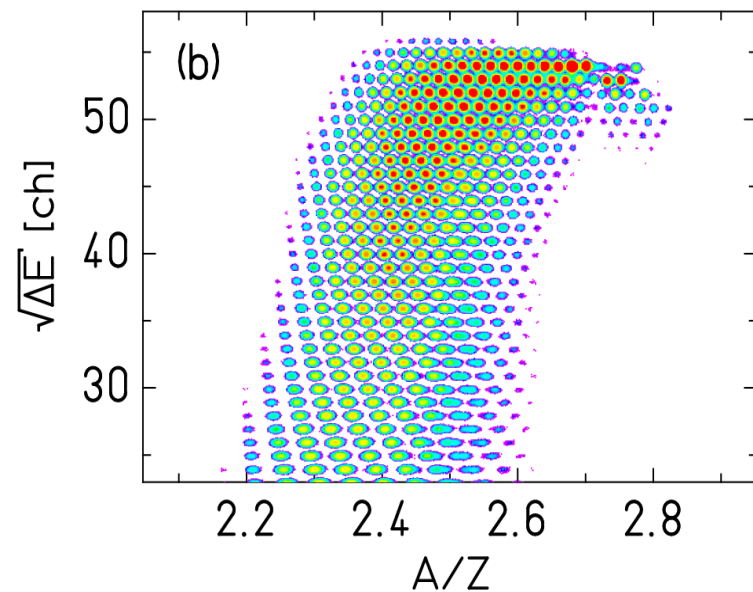
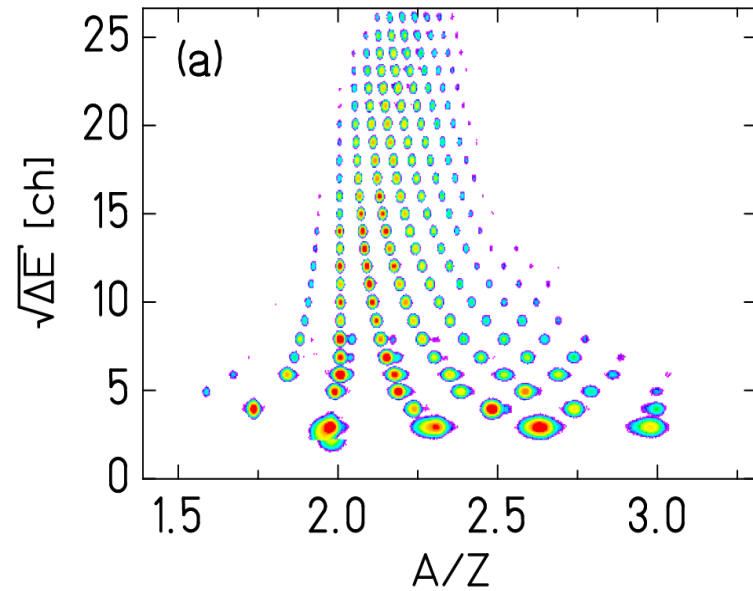

Overview experiment,  
covering all projectile-like  
residues.

Perfect identification  
in  $Z$  and  $A$  by ToF,  
magnetic deflection in FRS  
and energy loss in IC.

$^{136}\text{Xe}$  (1 A GeV) + Pb

D. Henzlova et al., 2008

# Nuclide cross sections in $^{136,124}\text{Xe} + \text{Pb}$

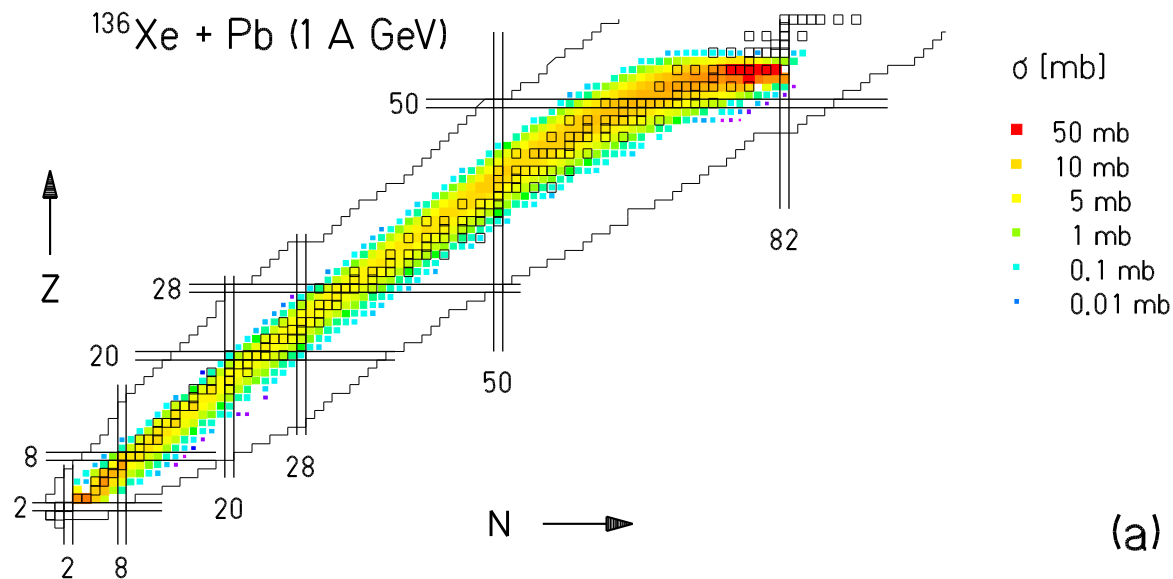

Production over the whole mass range below the projectile.

Strong memory on  $N/Z$  of projectile in heavy-mass range.

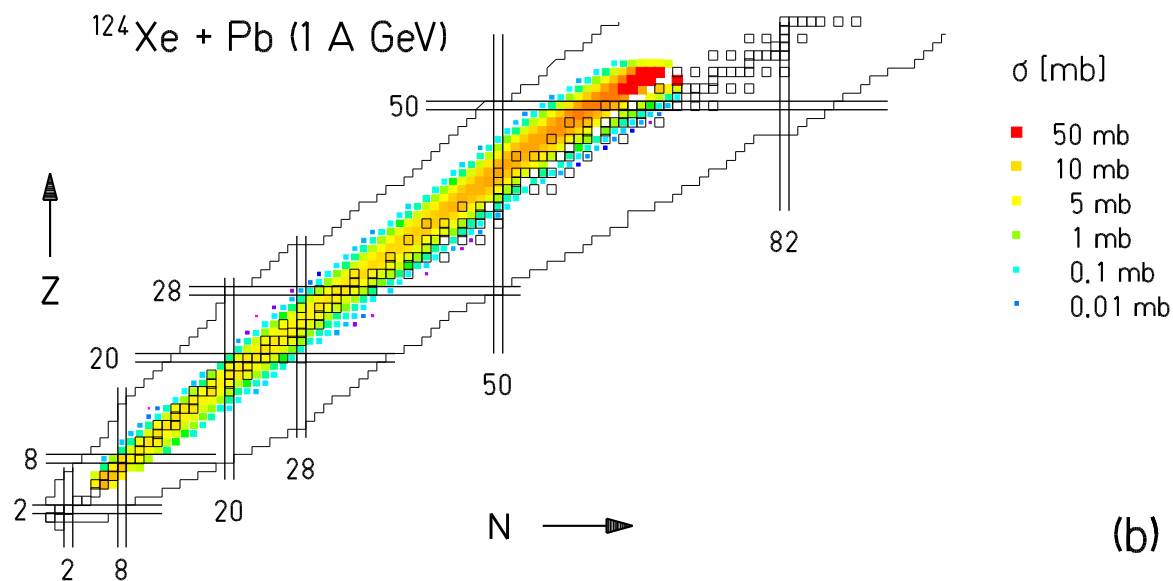

Approaching a universal “evaporation corridor”?

D. Henzlova et al., 2008

# Memory on $N/Z$ of projectile

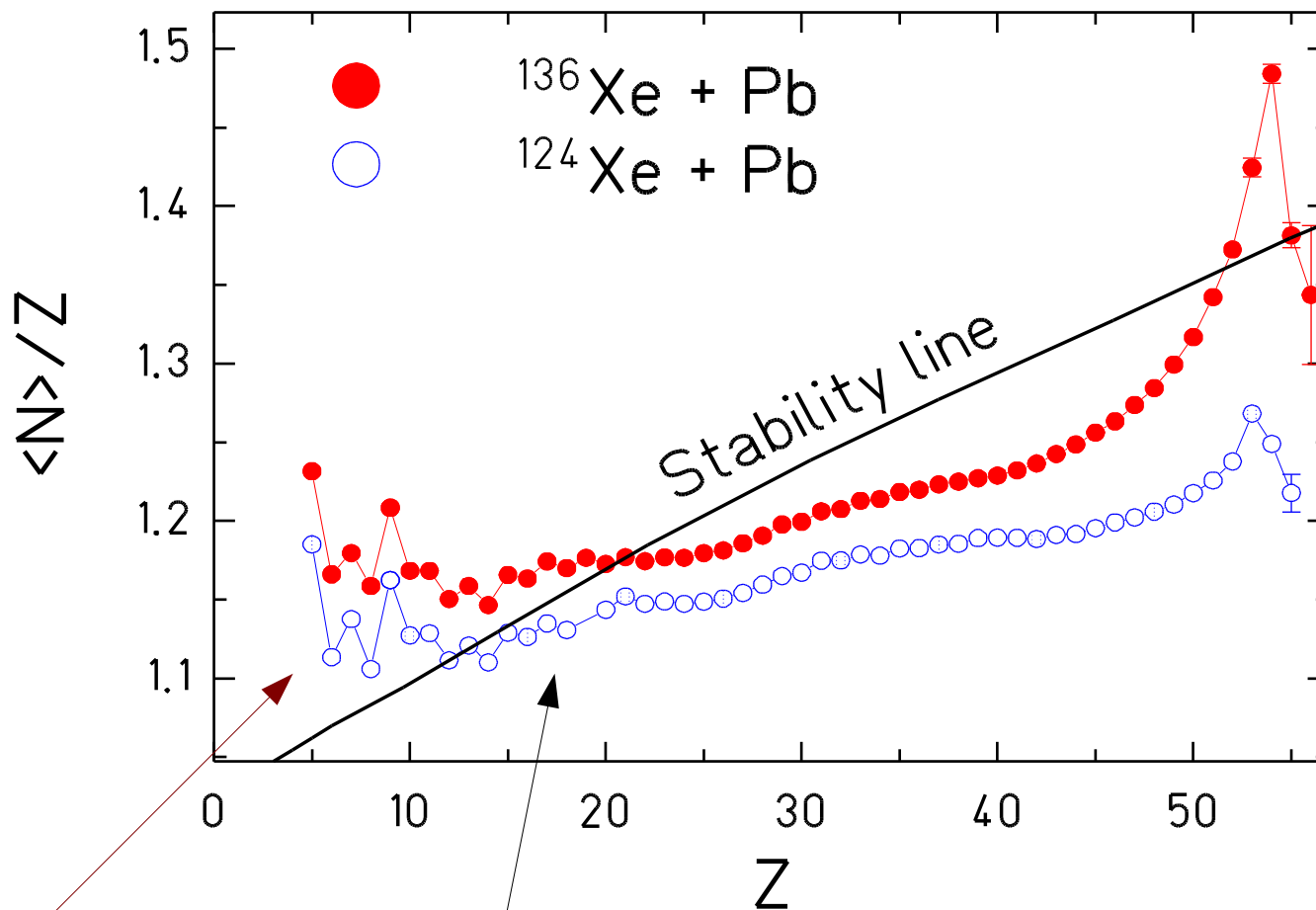

D. Henzlova, 2007

Staggering due to even-odd structure.

Information on symmetry energy in the de-excitation process.

# Experimental campaign on spallation cross sections

(motivated by ADS, EURISOL → one example)

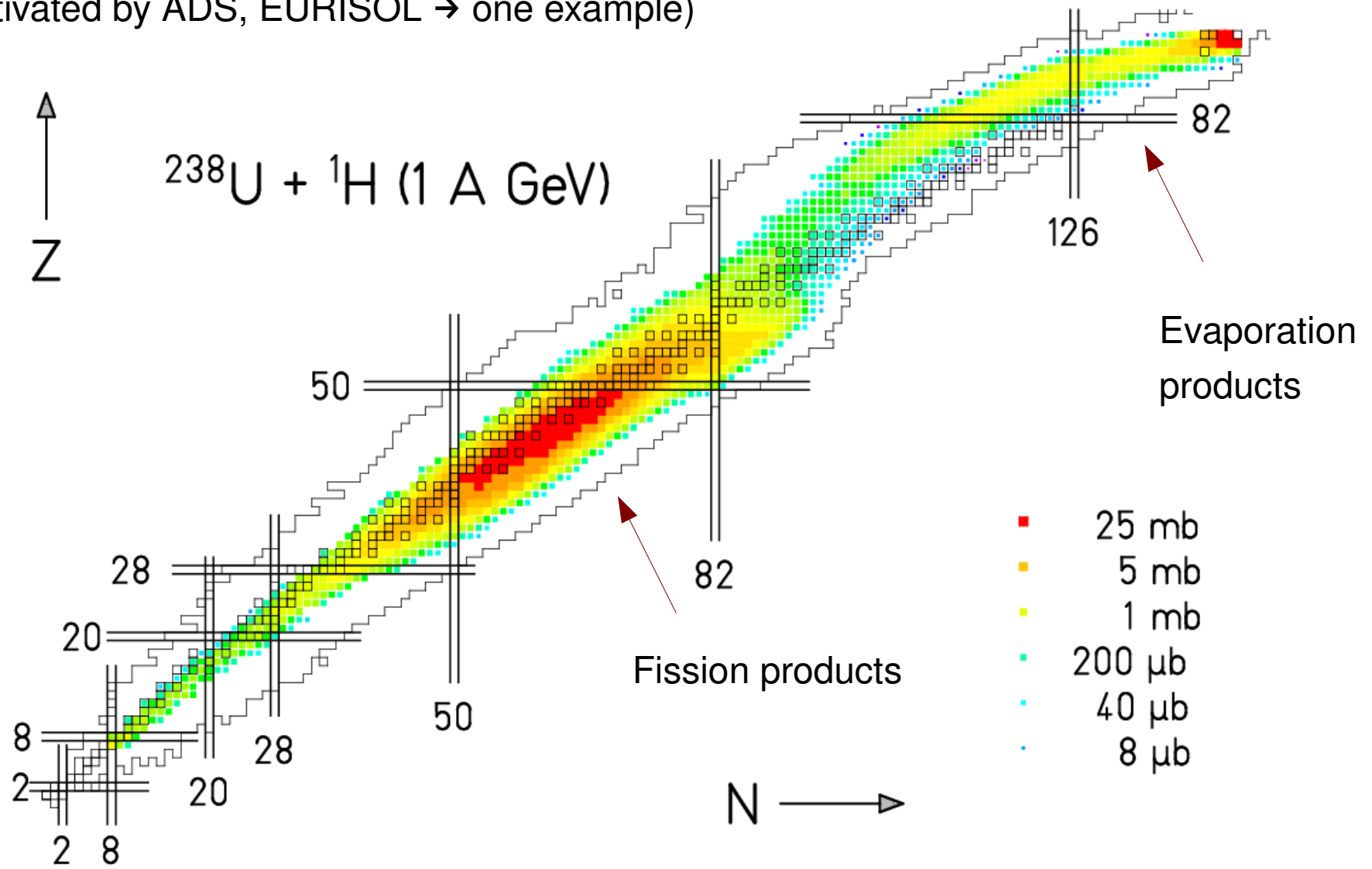

Good knowledge on in-target production in EURISOL.

Monique Bernas, Julien Taieb, Maria Valentina Ricciardi, 2003-2006

# Even-odd effect in production of light nuclei from violent collisions ( $^{238}\text{U}$ (1 A GeV) + Ti)

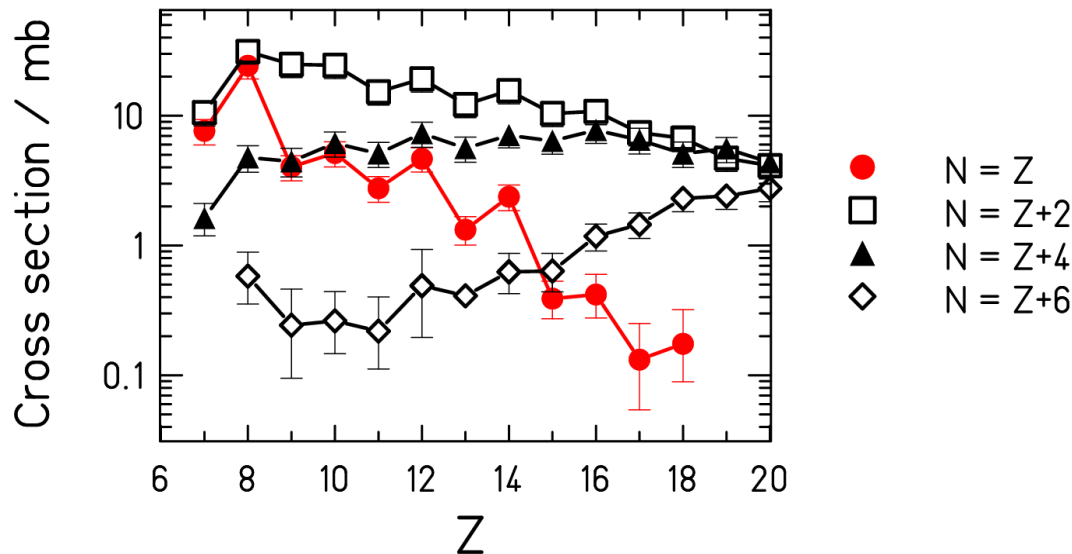

Observed fine structure in fragmentation

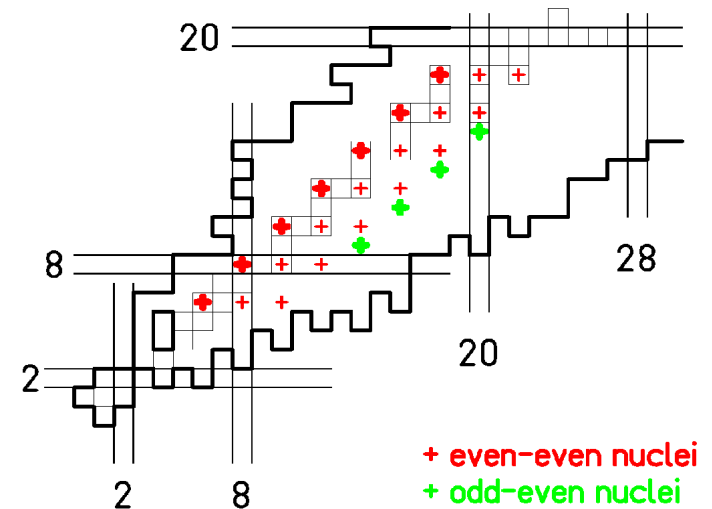

M. V. Ricciardi et al., 2004

Superfluidity is restored at the end of the evaporation cascade.  
 Complex interplay of pairing correlation (angular-momentum dependent),  
 Wigner term ( $N=Z!$ ), particle thresholds and gamma competition.  
 Mass information is crucial for revealing the full complexity.

# Layout

- **Nuclear-reaction schemes**
  - Beam energy and impact parameter
- **The fragment separator of GSI**
  - In-flight separator and energy-loss spectrometer
- **Experiments with separated secondary beams**
  - Fission channels
- **Production cross sections of individual nuclides**
  - Global features and nuclear-structure phenomena
- **High-precision experiments on longitudinal momentum**
  - Characterization of reaction channel, friction, re-acceleration, kinematics of multifragmentation

# Velocities of projectile residues

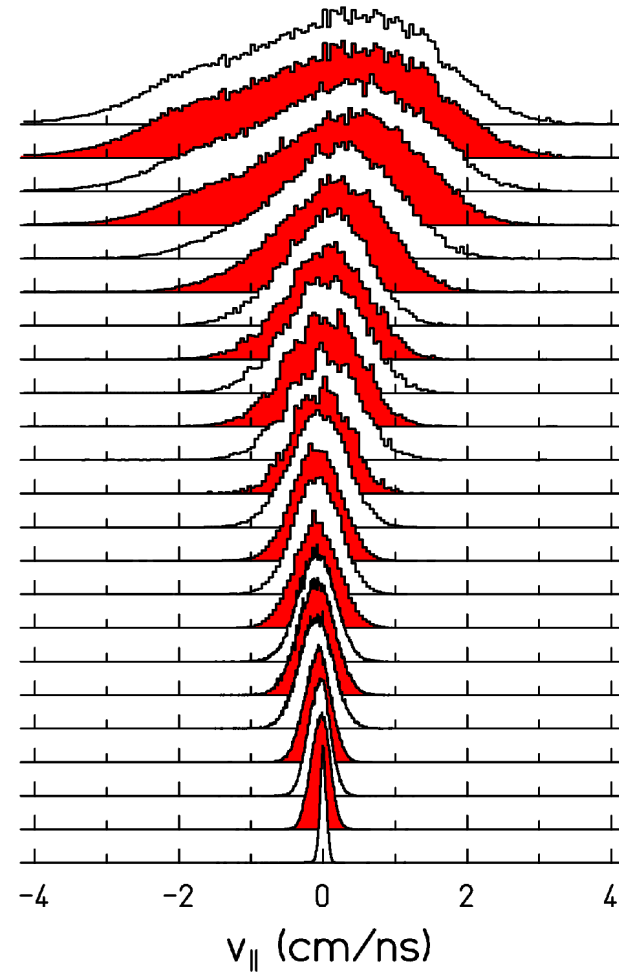
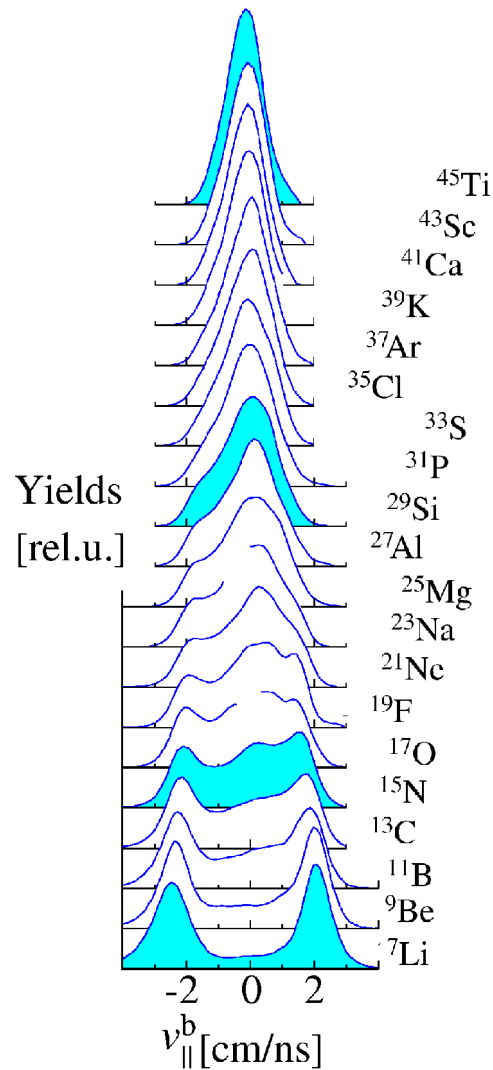

A=11

A=132

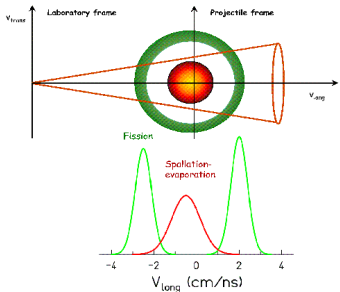

$^{136}\text{Xe}$  (1 A GeV) +  $^1\text{H}$

Paolo Napolitani et al, 2008

$^{136}\text{Xe}$  (1 A GeV) + Pb

Antoine Bacquias, 2008

$v$  distribution pins down the reaction channel: binary decay  $\rightarrow$  double peak

# Friction in very peripheral collisions

Reconstruction of  $\langle v_{\parallel} \rangle = f(b)$  from measured cross-section data. (A. Bacquias, 2008)

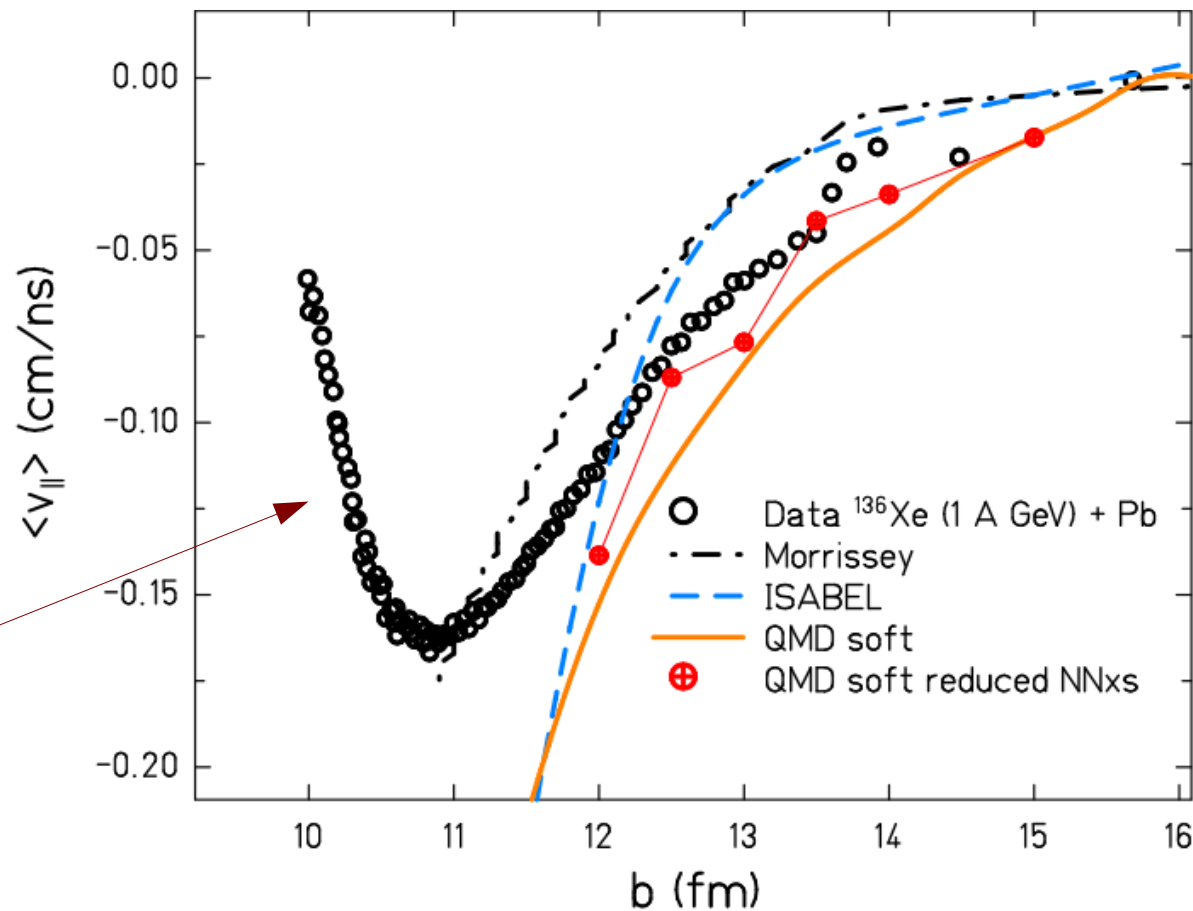

Re-acceleration in violent collisions.  
(Will be discussed later.)

Friction is sensitive to in-medium nucleon-nucleon cross section (Danielewicz).

QMD seems to need more numerical stability for calculating the small velocity shifts.

# Au (1 A GeV) + Au, velocity distributions

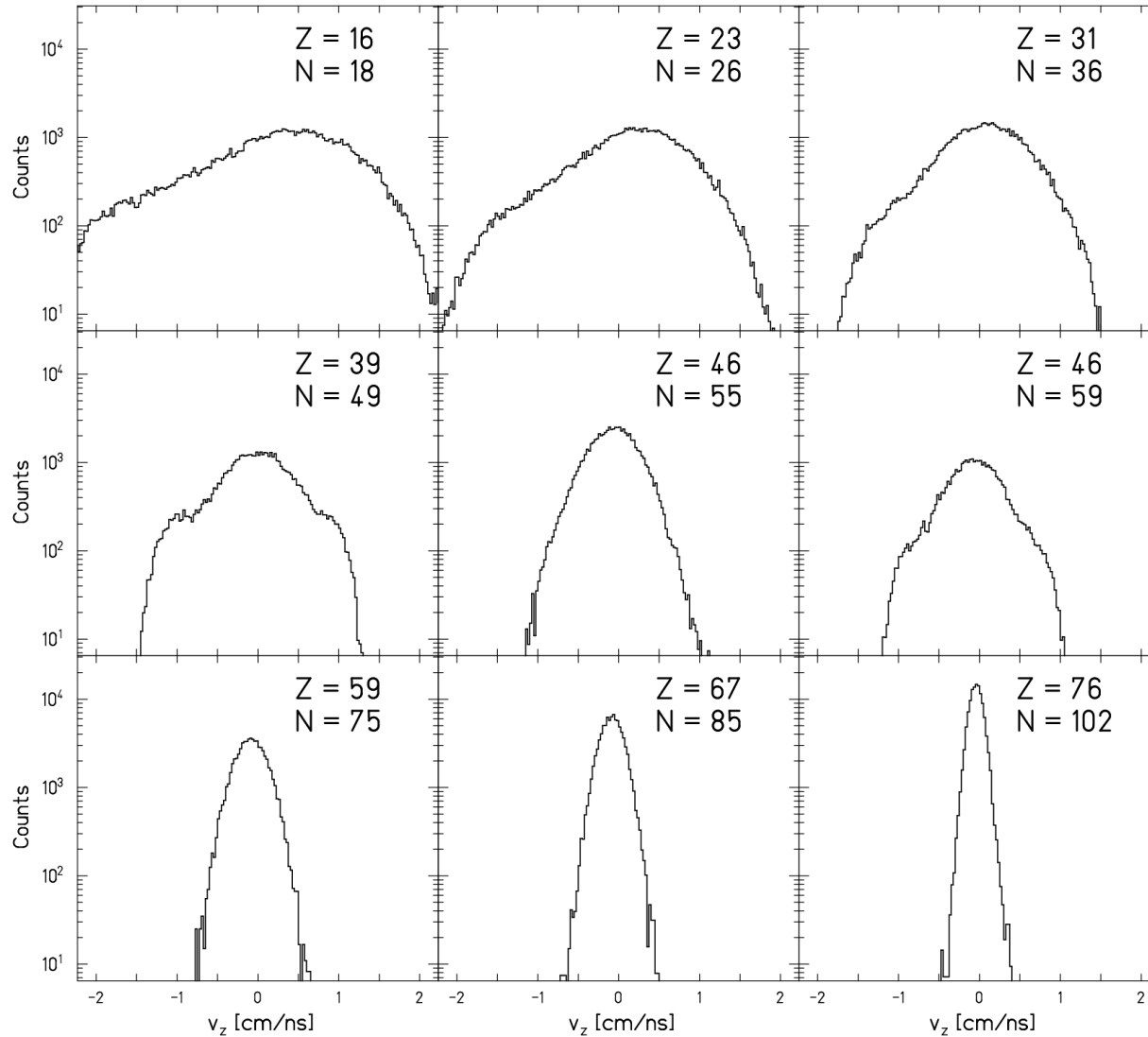

Systematic study of the re-acceleration phenomenon of light fragments.

# Re-acceleration of projectile spectators

## - dependence on energy and target mass

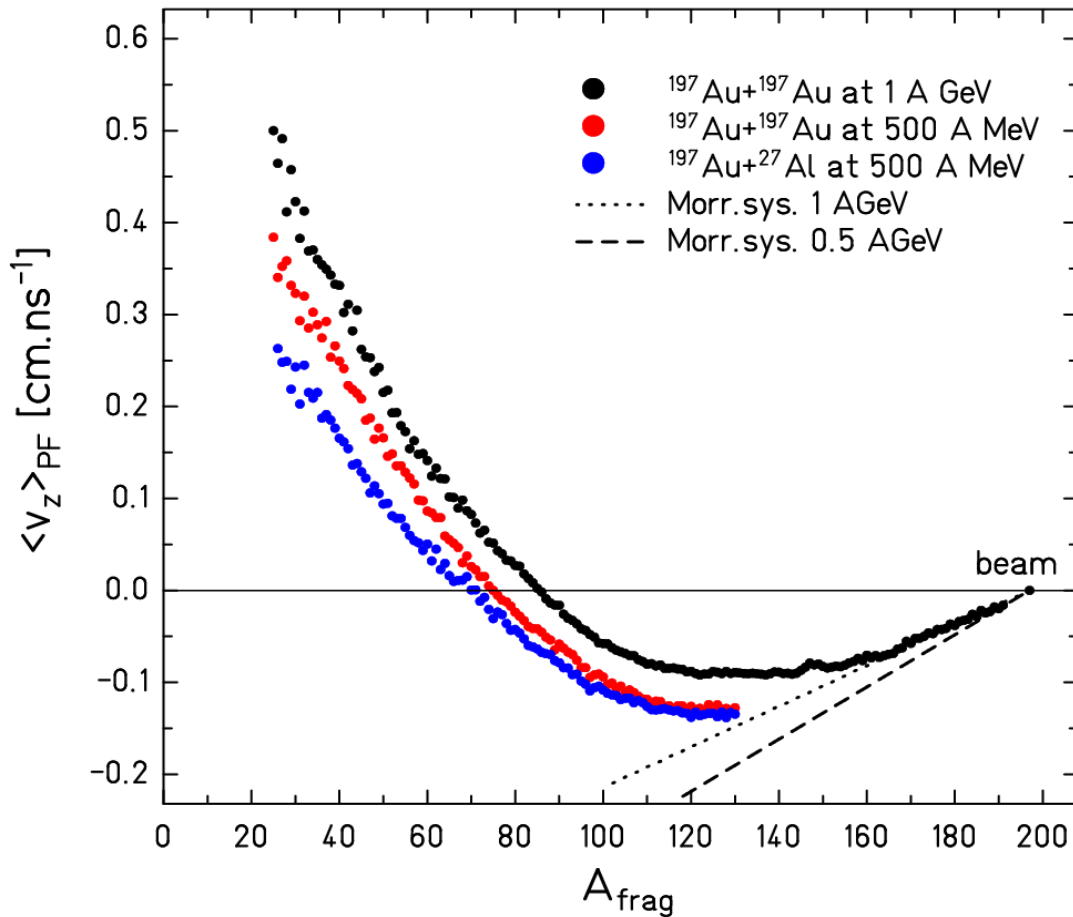

Reduction of the re-acceleration phenomenon with decreasing beam energy and lighter target mass.

V. Henzl, 2007

# Theory: Re-acceleration is the participant's blast to the spectator due to momentum-dependence of mean field

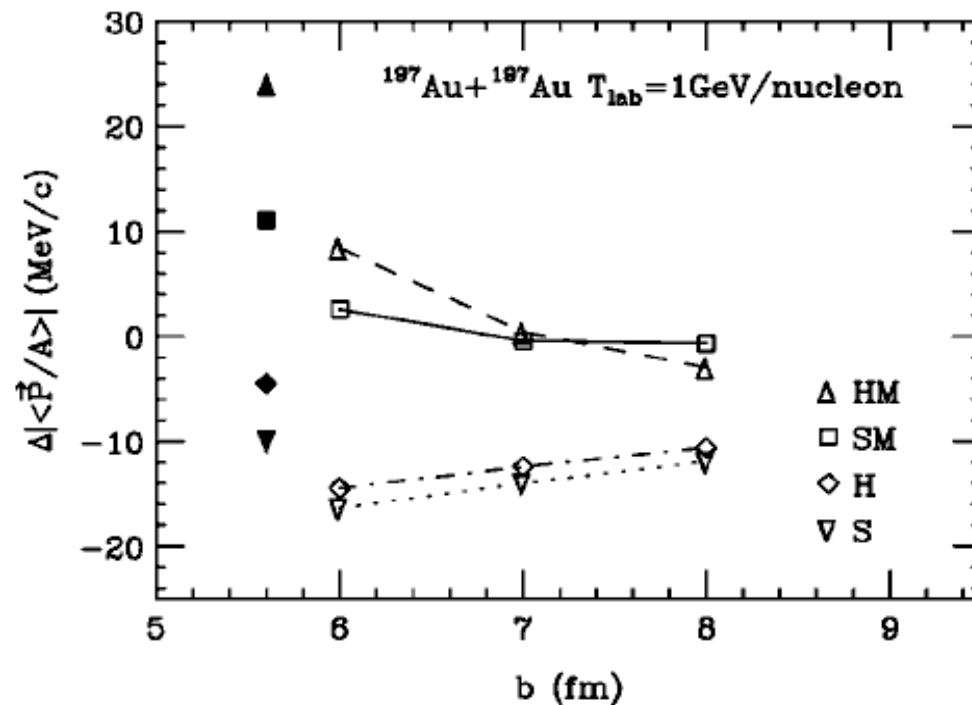

**H**ard and **S**oft equation of state, with and without **M**omentum-dependent mean field.

She, Danielewicz and Lacy, 2001

# Width of momentum distributions

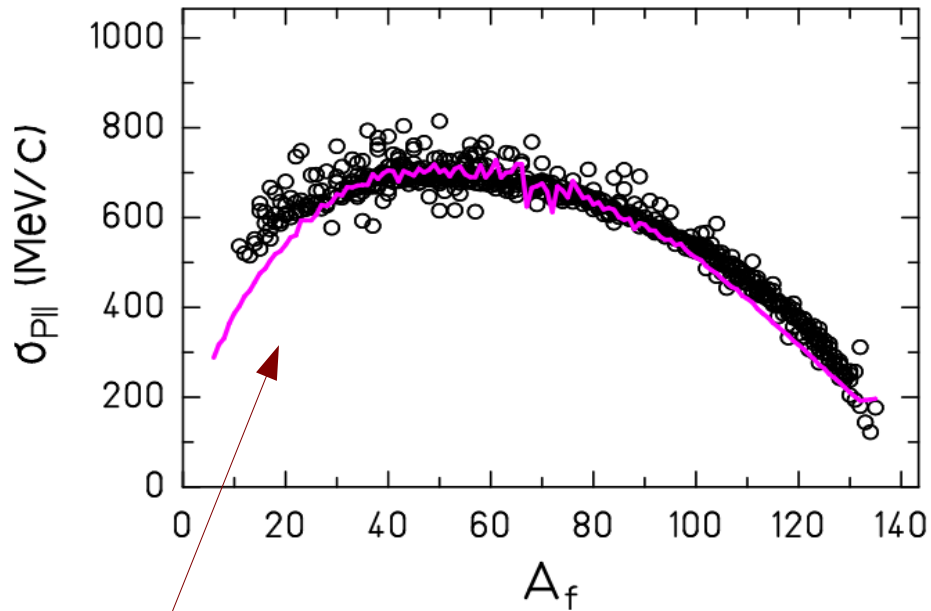

$^{136}\text{Xe}$  (1 A GeV) + Pb

Full calculation with ABRABLA reproduces the width of the momentum distributions. Fermi momentum of abraded nucleons is dominant, also in the multifragmentation regime.

Antoine Bacquias, 2008

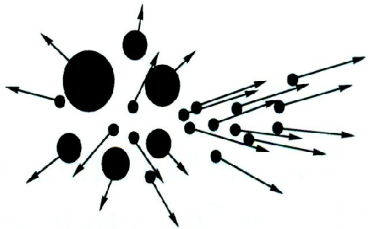

Multifragmentation

Almost insensitive to kinematics of multifragmentation  
→ Fermi momentum (Odeh et al., 2000) or thermal equilibrium (SMM)

## The CHARMS collaboration

Peter Armbruster, Antoine Bacquias, Lydie Giot, Vladimir Henzl, Daniela Henzlova, Alexander Karpov, Aleksandra Kelić, Strahinja Lukić, Pavel Nadtochy, Radek Pleskač, Maria Valentina Ricciardi, Karl-Heinz Schmidt, Florence Vivès , Bernd Voss, Orlin Yordanov, *GSI, Planckstr. 1, D-64291 Darmstadt*

Laurent Audouin, Charles-Olivier Bacri, Monique Bernas, Brahim Mustapha, Claude Stéphan, Laurent Tassan-Got, *IPN Orsay, B.P. n. 1, F-91406 Orsay, France*

Alain Boudard, Jean-Eriq Ducret, Beatriz Fernandez, Sylvie Leray, Claude Volant, Carmen Villagrasa, Wojczek Wlaslo, *DAPNIA/SPhN, CEA Saclay, F-91191 Gif sur Yvette Cedex, France*

Julien Taieb, *DEN/DM2S/SERMA/LENR, CEA Saclay, F-91191 Gif sur Yvette Cedex, France*  
Serge Czajkowski, Beatriz Jurado, Michael Pravikoff, *CENBG, Le Haut Vigneau, F-33175 Bordeaux-Gradignan, Cedex, France*

Paolo Napolitani, Fanny Rejmund, Christelle Schmitt, *GANIL, B.P. 5027, F-14076 Caen Cedex 5, France*

Jose Benlliure, Jorge Pereira, Enrique Casarejos, Manuel Fernandez, Teresa Kurtukian *Univ. Santiago de Compostela, E-15706 Santiago de Compostela, Spain*

Arnd Junghans, Forschungszentrum Rossendorf, *Postfach 510119, D-01314 Dresden, Germany*